

Tumble dryer

TD6-14



Dryer featuring exceptional savings and effortless use



Priority on people

Certified ergonomic design with a human-centered approach for an outstanding user experience

- Lint filter
The horizontal filter drawer is positioned for easy access and cleaning without the need to bend down



Long-term savings

Innovative features to save money and time, and embrace a sustainable lifestyle

- Moisture Balance (optional)
Helps to stop the drying process at the right time to save on energy costs



Pure control

Monitor your equipment and performance from anywhere, allowing to take action and to improve your business with OnE Laundry - the personal assistant for hygiene validation management, process management and revenue management (optional)



Outstanding productivity

Dry more laundry in less time: a game-changing improvement

- Reversing drum
Minimizes wrinkles and drying time to get an effective and even drying performance



Global Advanced Hygiene

Global Advanced Hygiene program package* with proven log 6 reduction** disinfection of textiles through the laundry process, fulfilling the criteria of all local approved standards

Main options and accessories

- Insulated glass door keeps the door cool on the outside and heat on the inside, so the room temperature is not affected
- Lagoon Advanced Care
- Drum Speed Control adjusts the movement of the drum to help garments move correctly for a faster drying process
- Door, front and side panels are available in stainless steel
- Connectable to booking-/payment system or coin meter
- Adaptive Fan Control - The Adaptive Fan Control adjusts the fan speed automatically to keep air flowing efficiently which will save energy and help to optimize the drying time. (Only available on electric heated machines)



Images shown are a representation of the product only and variations may occur. To get the door design you need to add the insulated glass.

* Programs available in the standard library of all products, excluding products for specific segments where water temperature is not controllable.

** Log 6 reduction equals to 99,999% viral infectivity reduction. The efficacy of reduction of SARS-CoV-2 and other pathogens in the process is confirmed by RISE (The Research Institute of Sweden) on the basis of Electrolux Professional laboratory data.

Main specifications			TD6-14				
Rated capacity, filling factor 1:18	kg/lb		14.2/31.3				
	kg/lb		11.6/25.6				
Drum volume	litre		255				
Drum diameter	mm		755				
Heating,	electric	kW	6.0/9.0/13.5				
	gas	BTU/h (kW)	46000 (13.5)				
	steam at 700 kPa		15.0				
Consumption data*			EI 6.0 kW	EI 9.0 kW	EI 13.5 kW	Gas	Steam
Total time full load	min		50	35.6	25.6	27.9	27.1
Energy consumption full load	kWh		5.5	5.7	5.8	6.5	7.1
Evaporation	g/min		115	163	226	208	214
Energy kWh/litre water evaporated	kWh/l		0.96	0.99	1.00	1.12	1.23

* At rated capacity 1:22, 100% cotton load at 50% initial moisture dried to 0%.

Electrical connections					
Heating alternative	Main voltage		Heating power kW	Total power kW	Recommended fuse A
		Hz			
Electric heated	220-240V 1 -	50/60	6.0	7.0	35
	220-230V 3 -	50/60	9.0/13.5	10.0/14.5	35/50
	240V 3 -	50/60	9.0/13.5	10.0/14.5	25/35
	380-415V 3N -	50/60	9.0/13.5	10.0/14.5	16/25
	440V 3 -	50/60	9.0/13.5	10.0/14.5	16/20
	480V 3 -	60	9.0/13.5	10.0/14.5	16/20
Gas heated/ Steam heated	220-240V 1 -	50/60	*	1.2	10
	220-240V 3 -	50/60	*	1.0	10
	380-415V 3N -	50/60	*	1.0	10
	440V 3 -	50/60	*	1.0	10
	480V 3 -	60	*	1.0	10

* Total power and recommended fuse does not depend on the heating power in those cases.

Steam, gas and air connections			TD6-14
Steam	ISO 7/1-R		1"
Steam pressure	kPa		100-1000
Steam consumption	kg/h		65
Condensate	ISO 7/1-R		1"
Gas	ISO 7/1-R		1/2"
Gas pressure	Natural gas	Pa	2000
		mbar	20
	Propane	Pa	2800-5000
		mbar	28-50
Air outlet		ø mm	200
Evacuated air,	el 6.0/9.0 kW el 13.5 kW gas 13.5 kW steam 15.0 kW		260
			360
			360
			420
			420
Pressure drop	el 6.0/9.0 kW el/gas 13.5 kW steam 15.0 kW	Max. Pa	750
			650
			650
Sound levels			
Sound power/pressure level at drying*		dB(A)	72/56
Heat emission			
% of installed power, max			15
Shipping data**			
Weight		kg	222
Shipping volume		crated, m ³	1.70
Dimensions in mm			
A	Width		790
B(a)	Depth, el and gas		965
B(b)	Depth, steam		1105
C	Height		1770
D			775
E			835
F			750
G			110
H			60
I			270
J			240
K			175
L			605
M			740
N			395
1	Operating panel		
2	Door opening ø 580 mm		
3	Electrical connection on gas heated machines		
4	Gas connection/Electrical connection on electrical heated machines		
5	Exhaust connection		
6	Condensate connection		
7	Steam connection		

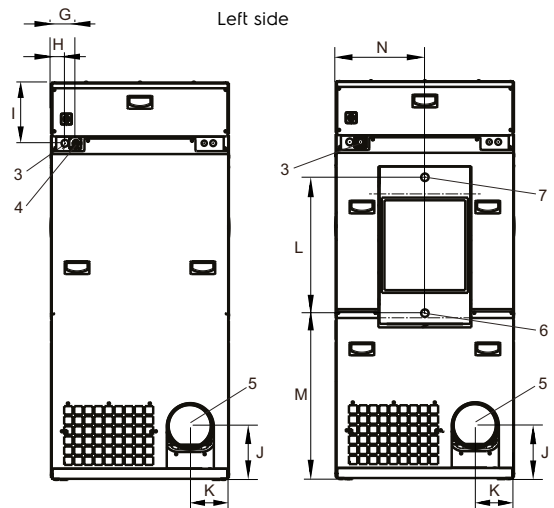
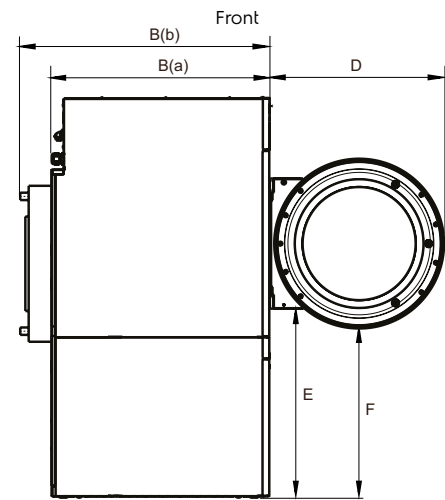
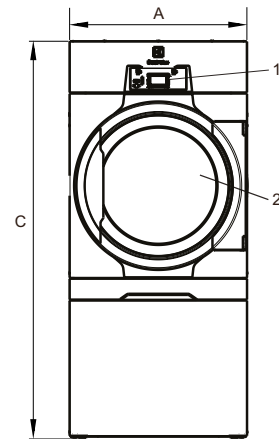

El, gas

Steam

Rear side

Front and side panels in silver grey and dark blue (color samples can be ordered on part number 472998313).

* Sound power levels measured according to ISO 60704.

** Average data. Crated weight/shipping volume depends on configuration. Please contact logistics for exact measures.