

Warewashing
Undercounter for 600x400 mm trays,
double skin, atmospheric boiler,
30baskets/h

ITEM # _____

MODEL # _____

NAME # _____

SIS # _____

AIA # _____

402313 (EXLIG)

Undercounter Dishwasher for 600x400 mm trays, with double skin, atmospheric boiler, drain pump and detergent dispenser, capacity per hour of 30 baskets or 540 dishes or 120

Short Form Specification

Item No. _____

Unit shall be undercounter dishwasher type hot water rinsing using rack dimension of 500*500mm or 500*600mm with Atmospheric boiler. Electrical characteristics to be 400 volts three phase 50Hz operation, convertible to single phase on-site. Washing performance is ensure by a powerful wash pump, large capacity wash tank, upper and lower revolving spray arms. Constant rinse temperature and pressure guaranteed by built-in atmospheric boiler and rinse booster pump. The unit designed to wash 600x400mm trays and allows the use of standard 500*500mm racks. Four automatic cycles for different types of wares. Double skin insulated, counter-balance door. Double skin cabinet. Pressed wash tank with round corners. 304 AISI stainless steel construction to include door, external panels, frame, wash tank, tank filters, wash arms and rinse arms. Electronic control with temperature display. Automatic self-cleaning cycle. The unit shall include drain pump and rinse aid dispenser pump and is equipped with electric cable.

Main Features

- Washing system endowed with rotating washing arms, high powered wash pump and large capacity boiler for professional washing.
- Simple service from the front.
- Double skinned insulated wall ensures a low noise level and a reduction in heat loss from the machine.
- Low noise level.
- Built-in rinse aid and detergent dispenser with automatic initial and continuous cycle loading for perfect result while minimizing service and maintenance needs.
- Three phase or single phase electrical connection, convertible on-site.
- Easy to remove wash/rinse arms for cleaning.
- Built-in atmospheric boiler with rinse booster pump to provide constant water temperature and pressure for rinsing, independent from water inlet.
- A pause of a few seconds after washing and before rinsing ensures that no drops of unclean water will fall on the clean items at the end of the rinsing cycle.
- Large washing chamber is suitable for both 500x500 mm standard baskets and 600x500 mm baskets to wash 600x400 mm trays.
- Electronic control panel with temperature display to easily operate and monitor machine status.
- Equipped with drain pump for easy and quick installation without opening the machine.
- Built-in atmospheric boiler sized to raise incoming water to 84 °C minimum for sanitizing rinse. No external booster is required.
- Washing capacity of 30 baskets per hour.

Construction

- Unit to feature smooth surfaces to facilitate cleaning.
- Completely closed on the back by a cover plate.
- Large deep drawn wash tank and internal wash area with round corners and no pipes to avoid dirt built-up.
- Large tank filter collects the soil to keep the wash water clean for a longer time and have better washing performance.
- Front panel, door, wash tank, tank filters, wash arms and rinse arms made in heavy duty anti-corrosive 304 AISI stainless steel.
- Unit to feature rinse aid and detergent dispenser pumps.
- Insulated double skin door construction preserves heat inside the tank to lower energy consumption and the noise. Counter-balance mechanism minimizes impact when opening and closing.

Included Accessories

- 1 of Stainless steel support for 4pcs of 600x400mm trays for Pastry Line Undercounter Dishwasher PNC 867073

APPROVAL: _____



Electrolux
PROFESSIONAL

Warewashing
Undercounter for 600x400 mm trays, double
skin, atmospheric boiler, 30baskets/h

- 1 of Plastic rack (600x500mm) for PNC 867074
utensils for Pastry Line Undercounter
Dishwasher

Optional Accessories

- Stainless steel support for 6pcs of PNC 867075
600x400mm trays for Pastry Line
Undercounter Dishwasher
- Stand for Pastry Line Undercounter PNC 867076
Dishwasher



Warewashing
Undercounter for 600x400 mm trays, double skin, atmospheric boiler,
30baskets/h
The company reserves the right to make modifications to the products
without prior notice. All information correct at time of printing.

2023.03.15



Electrolux
PROFESSIONAL

Warewashing
Undercounter for 600x400 mm trays, double
skin, atmospheric boiler, 30baskets/h

Front

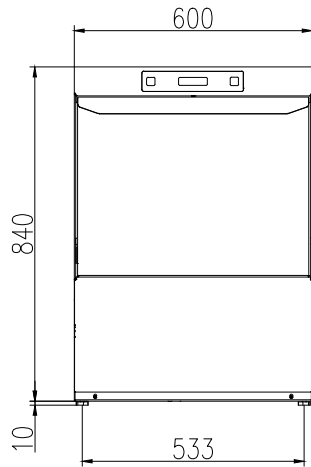

Side

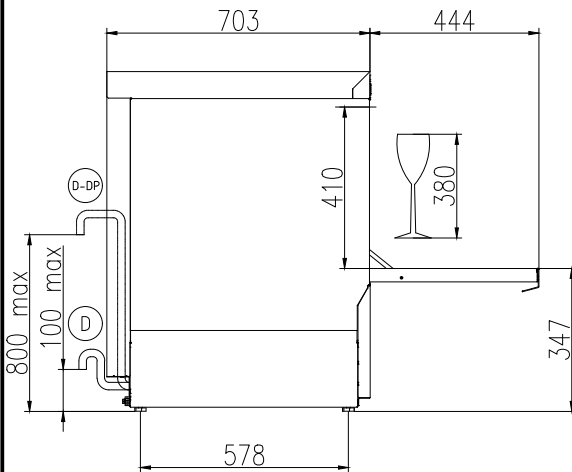

- | | |
|--------------------------------------|---------------------------|
| CW11 = Cold Water inlet 1 (cleaning) | XD = Detergent connection |
| D = Drain | XR = Rinse aid connection |
| EI = Electrical inlet (power) | |
| EO = Electrical Outlet | |
| HWI = Hot water inlet | |
| WI = Water inlet | |

Electric

Supply voltage:	
402313 (EXLIG)	380-415 V/3N ph/50 Hz
Default Installed Power:	6.65 kW
Boiler heating elements:	6 kW
Tank heating elements:	2.4 kW
Wash pump size:	0.68 kW

Water:

Pressure, bar min/max:	1-6 bar
Water supply temperature*:	10-50 °C
Drain line size:	29mm
Inlet Water supply pressure:	15 - 87 psi (1 - 6 bar)
Washing tank capacity (lt):	22
Water consumption per cycle (lt):	2.2
Boiler Capacity (lt):	5.5

Key Information:

Baskets per hour*:	30
Dishes per hour:	540
Working cycles time (sec.):	120/180/360/540
Wash temperature:	55-65°C
Cell dimensions - width:	500 mm
Cell dimensions - depth:	600 mm
Cell dimensions - height:	410 mm
Rinse temperature:	85 °C
External dimensions, Width:	600 mm
External dimensions, Depth:	703 mm
External dimensions, Height:	850 mm
Packaging size (WxDxH):	690x790x1000 mm
Noise level:	61,3 dBA



Warewashing
Undercounter for 600x400 mm trays, double skin, atmospheric boiler,
30baskets/h
The company reserves the right to make modifications to the products
without prior notice. All information correct at time of printing.