

Smart Steam Crosswise Ovens Electric Convection Oven, 10 GN1/1 smart steam

ITEM # _____

MODEL # _____

NAME # _____

SIS # _____

AIA # _____

260691 (EFCE11SSDS)

 Smart Steam Convection
 Oven Crosswise 10 GN 1/1,
 electric

Short Form Specification

Item No.

Convection oven with direct steam. Main structure in stainless steel. Cooking chamber in 304 AISI stainless steel and side lighting. Double glass door with double-step opening and drip trays under the cooking chamber and under the door. Heating via "Incoloy" armoured elements positioned on the convector unit. Electromechanical thermostat; temperature adjustable from 30°C to 300°C; visual display and thermometer. Single sensor probe. Timer from 0 to 120 minutes with acoustic alarm. 5-level humidity control.

Supplied with n. 1 "cross-wise" tray rack composed by 2 side hangers, 60 mm pitch, for 10x1/1GN grids.

Main Features

- Main switch/Cooking mode selector which can be used to set: ON/OFF, hot air without humidification and hot air with humidification (choice of 5 different humidity levels).
- Rapid cooling of oven cavity.
- Timer to set the cooking time, adjustable up to 120 minutes or for continuous operation with an acoustic alarm to show the cycle has finished. At the end of the set cooking time the heat and the fan are automatically switched off.
- Maximum temperature of 300°C.
- Perfect evenness: guarantees perfect distribution of heat throughout the oven cavity.
- Halogen lighting and "crosswise" pan supports allow clear and unobstructed view of the products being cooked.
- Core temperature probe.
- Drip tray to collect residual cooking juices and fat.
- Drip tray under the door to collect condensed liquid.
- Double step opening to avoid accidental heat release.
- Manual valve to adjust the position of steam evacuation flap.
- Capacity: 10 GN 1/1 trays.

Construction

- Robust structure thanks to stainless steel construction.
- Cooking chamber in 304 AISI stainless steel.
- Double thermo-glazed door with open frame construction, for cool outside door panel. Swing hinged easy-release inner glass on door for easy cleaning.
- Ergonomic door handle.
- Integrated drain outlet.
- 1 pair of 60 mm pitch runners is supplied as standard.
- IPx4 water protection.

APPROVAL: _____

Included Accessories

- 1 of 60mm pitch side hangers 10x1/1GN electric oven (included with the oven) PNC 922121

Optional Accessories

- 12lt external manual water softener PNC 860412
- Pair of 1/1GN AISI 304 stainless steel grids PNC 921101
- Support for 1/2GN pan (2pcs) PNC 921106
- Water softener with salt for ovens with automatic regeneration of resin PNC 921305
- Guide kit for 1/1GN drain pan PNC 921713
- Pair of AISI 304 stainless steel grids, GN 1/1 PNC 922017
- Pair of grids for whole chicken (8 per grid - 1,2kg each), GN 1/1 PNC 922036
- AISI 304 stainless steel grid, GN 1/1 PNC 922062
- Open base for 10 GN 1/1 convection oven PNC 922102
- Shelf guides for 10x1/1GN, ovens base PNC 922106
- Cupboard base for 10 GN 1/1 convection oven PNC 922109
- 80mm pitch side hangers 10x1/1GN electric oven PNC 922115
- 60mm pitch side hangers 10x1/1GN electric oven (included with the oven) PNC 922121
- Feet for convection ovens 10 GN1/1 & 10 GN2/1 PNC 922127
- Trolley for 10x1/1GN and 10x2/1GN roll-in rack PNC 922128
- Trolley for 10x1/1GN roll-in rack PNC 922130
- Retractable hose reel spray unit PNC 922170
- External side spray unit (needs to be mounted outside and includes support to be mounted on the oven) PNC 922171
- Fat filter for 10 1/1 and 2/1 GN combi steamers (gas and electric) and convection ovens (electric) PNC 922178
- Kit to convert to 10x1/1GN roll-in rack PNC 922201
- Pair of frying baskets PNC 922239
- Grid for whole chicken (8 per grid - 1,2kg each), GN 1/1 PNC 922266
- Kit universal skewer rack and 6 short skewers for Lengthwise and Crosswise ovens PNC 922325
- Universal skewer rack PNC 922326
- 6 short skewers PNC 922328
- Volcano Smoker for lengthwise and crosswise oven PNC 922338
- Mesh grilling grid, GN 1/1 PNC 922713
- Non-stick universal pan, GN 1/1, H=20mm PNC 925000
- Non-stick universal pan, GN 1/1, H=40mm PNC 925001
- Non-stick universal pan, GN 1/1, H=60mm PNC 925002
- Double-face griddle, one side ribbed and one side smooth, GN 1/1 PNC 925003
- Aluminum grill, GN 1/1 PNC 925004
- Frying pan for 8 eggs, pancakes, hamburgers, GN 1/1 PNC 925005

Front

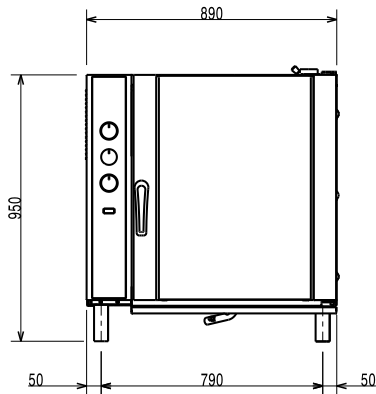

Side

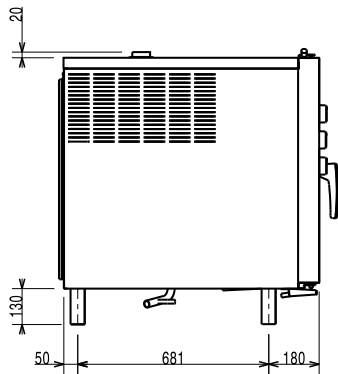

CWI1 = Cold Water inlet 1 (cleaning)
 CWI2 = Cold Water Inlet 2 (steam generator)
 D = Drain
 EI = Electrical inlet (power)

Top

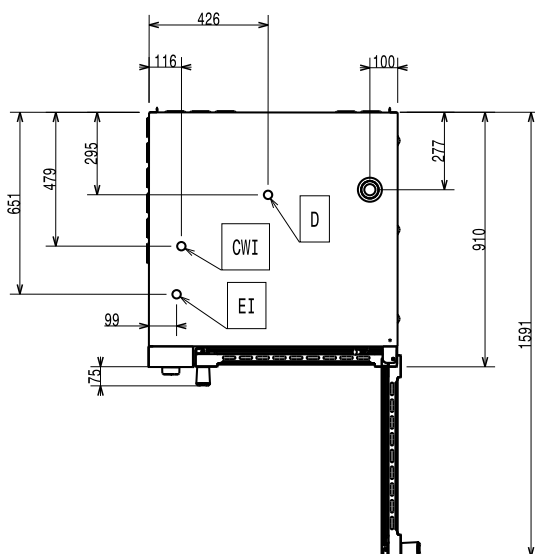

Electric

Supply voltage:	260691 (EFCE11SSDS)	380-400 V/3N ph/50 Hz
Electrical power max.:		17.3 kW
Total Watts:		17.3 kW

Capacity:

Trays type:	10 - 1/1 Gastronorm
-------------	---------------------

Key Information:

External dimensions, Width:	890 mm
External dimensions, Depth:	900 mm
External dimensions, Height:	970 mm
Net weight:	121.2 kg
Runners pitch:	60 mm
Convection:	X
Meat probe:	X
Internal dimensions, Width:	590 mm
Internal dimensions, Depth:	503 mm
Internal dimensions, Height:	680 mm