

## Crosswise Convection Gas Convection Oven, 6 GN1/1

ITEM # \_\_\_\_\_

MODEL # \_\_\_\_\_

NAME # \_\_\_\_\_

SIS # \_\_\_\_\_

AIA # \_\_\_\_\_

**260813 (EFCG61CSAS)**

 Convection Oven Crosswise  
 6x1/1GN, gas

### Short Form Specification

Item No. \_\_\_\_\_

Convection oven with direct steam. Main structure in stainless steel. Cooking chamber with side lightning and drip tray. Double glass door. Heating via atmospheric burners with flame failure device. Main burner with pilot light and piezoelectric ignition. Electromechanical thermostat; temperature adjustable from 30°C to 300°C. Timer from 0 to 120 minutes with acoustic alarm. 5-level humidity control. Supplied with n. 1 "cross-wise" tray rack composed by 2 side hangers, 60 mm pitch, for 6x1/1GN grids.

### Main Features

- Main switch/Cooking mode selector which can be used to set: ON/OFF, hot air without humidification and hot air with humidification (choice of 5 different humidity levels).
- Rapid cooling of oven cavity.
- Timer to set the cooking time, adjustable up to 120 minutes or for continuous operation with an acoustic alarm to show the cycle has finished. At the end of the set cooking time the heat and the fan are automatically switched off.
- Maximum temperature of 300°C.
- Perfect evenness: guarantees perfect distribution of heat throughout the oven cavity.
- Halogen lighting and "crosswise" pan supports allow clear and unobstructed view of the products being cooked.
- Food temperature probe (available as accessory).
- Drip tray to collect residual cooking juices and fat.
- Drip tray under the door to collect condensed liquid available as accessory.
- Capacity: 6 GN 1/1 trays.

### Construction

- Robust structure thanks to stainless steel construction.
- Cooking chamber in 430 AISI stainless steel.
- Double thermo-glazed door with open frame construction, for cool outside door panel. Swing hinged easy-release inner glass on door for easy cleaning.
- Ergonomic door handle.
- Integrated drain outlet.
- 1 pair of 60 mm pitch runners is supplied as standard.
- IPx4 water protection.

APPROVAL: \_\_\_\_\_

**Optional Accessories**

- Stacking kit for 6 GN 1/1 convection oven on 15&25 kg blast chiller/freezer crosswise PNC 881528
- Pair of 1/1GN AISI 304 stainless steel grids PNC 921101
- Support for 1/2GN pan (2pcs) PNC 921106
- Water softener with salt for ovens with automatic regeneration of resin PNC 921305
- Flue condenser for gas ovens 10x1/1-2/1 PNC 921701
- Probe for ovens 6 and 10x1/1GN PNC 921702
- Guide kit for 1/1GN drain pan PNC 921713
- Pair of grids for whole chicken (8 per grid - 1,2kg each), GN 1/1 PNC 922036
- Open base for 6 GN 1/1 convection oven PNC 922101
- Shelf guides for 6x1/1GN, ovens base PNC 922105
- Retractable hose reel spray unit PNC 922170
- External side spray unit (needs to be mounted outside and includes support to be mounted on the oven) PNC 922171
- Pair of frying baskets PNC 922239
- Grid for whole chicken (8 per grid - 1,2kg each), GN 1/1 PNC 922266
- Kit universal skewer rack and 6 short skewers for Lengthwise and Crosswise ovens PNC 922325
- Universal skewer rack PNC 922326
- Volcano Smoker for lengthwise and crosswise oven PNC 922338

Front

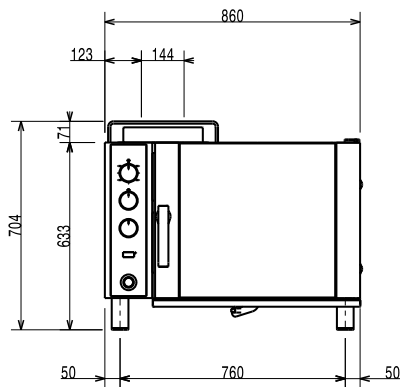

Side

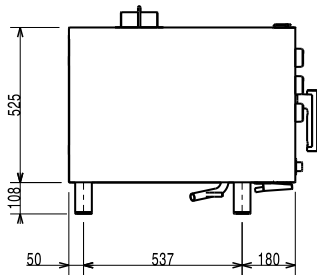

CW11 = Cold Water inlet 1 (cleaning)      G = Gas connection  
 CW12 = Cold Water Inlet 2 (steam generator)  
 D = Drain  
 EI = Electrical inlet (power)

Top

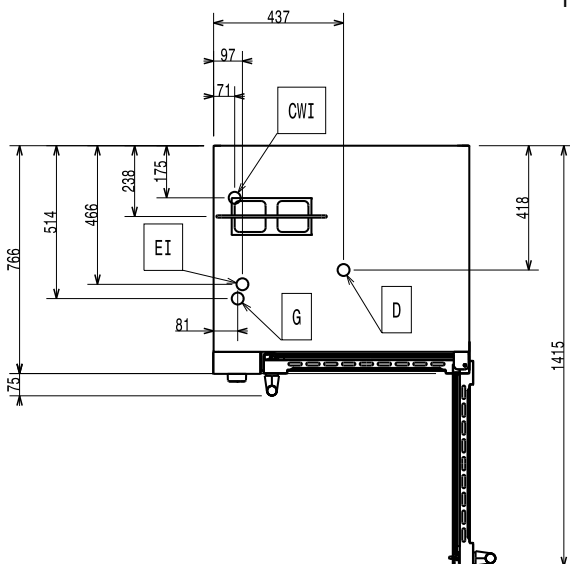

### Electric

#### Supply voltage:

260813 (EFCG61CSAS)      220-230 V/1 ph/50 Hz

#### Electrical power max.:

0.35 kW

### Capacity:

#### Trays type:

6 - 1/1 Gastronorm

### Key Information:

External dimensions, Width: 860 mm

External dimensions, Depth: 746 mm

External dimensions, Height: 701 mm

Net weight: 92.1 kg

Functional level: Basic

Cooking cycles - air-convection: 300 °C

Heating-up time (hot air cycle): 215°C / 350s.