



Modular Cooking Range Line 900XP 2-Eco Burner Gas Boiling Top, 10 kW

ITEM # _____

MODEL # _____

NAME # _____

SIS # _____

AIA # _____



391640 (E9AAQAAOMC)

2-Burner EcoFlame (10 kW each) gas Boiling Top

Short Form Specification

Item No. _____

To be installed on open base installations, bridging supports or cantilever systems. High efficiency flower flame burners with continuous power regulation and optimized combustion. Flame failure device as standard on burners to protect against accidental extinguishing. EcoFlame pan detection system to save energy and to reduce unnecessary heat radiation in the kitchen. Exterior panels of unit in stainless steel with Scotch Brite finish. Pan supports in heavy duty cast iron. Extra strength work top in heavy duty 2 mm stainless steel. Right-angled side edges to allow flush-fitting junction between units.

Main Features

- Unit to be mounted on open base cupboards, bridging supports or cantilever systems.
- The two 10 kW high efficiency burners are available in 100 mm diameter with continuous power regulation from 2.2 kW to 10 kW.
- Gas appliance supplied for use with natural or LPG gas, conversion jets supplied as standard.
- Large sized pan support in cast iron (stainless steel as option) with long center fins to allow the use of the largest down to the smallest pans.
- Burners with optimized combustion.
- Flame failure device on each burner protects against gas leakage when accidental extinguishing of the flame occurs.
- Protected pilot light.
- The special design of the control knob system guarantees against water infiltration.
- IPX5 water protection.
- Suitable for countertop installation.
- Control knobs provide smooth, continuous rotation from min to max power level.

Construction

- Unit is 930 mm deep to give a larger working surface area.
- All exterior panels in Stainless Steel with Scotch Brite finishing.
- AISI 304 stainless steel worktop, 2mm thick.
- Model has right-angled side edges to allow flush fitting joints between units, eliminating gaps and possible dirt traps.

Sustainability

- Model is supplied with EcoFlame pan detection system, which reduces energy consumption - up to 20%* in gas savings - and unnecessary heat dispersion in the kitchen. (* based on internal tests performed by professional chefs in comparison vs correspondent model without EcoFlame).

APPROVAL: _____



Experience the Excellence
www.electroluxprofessional.com

Optional Accessories

- Junction sealing kit PNC 206086
- Draught diverter, 120 mm diameter PNC 206126
- Matching ring for flue condenser, 120 mm diameter PNC 206127
- Support for bridge type installation, 800mm PNC 206137
- Support for bridge type installation, 1000mm PNC 206138
- Support for bridge type installation, 1200mm PNC 206139
- Support for bridge type installation, 1400mm PNC 206140
- Support for bridge type installation, 1600mm PNC 206141
- Support for bridge type installation, 400mm PNC 206154
- Single burner smooth plate for direct cooking - fits frontal burners only PNC 206171
- Single burner ribbed plate for direct cooking - fits frontal burners only PNC 206172
- Water column with swivel arm (water column extension not included) PNC 206289
- Water column extension for 900 line PNC 206290
- Stainless steel double grid for 2 burners PNC 206298
- Chimney upstand, 400mm PNC 206303
- Back handrail 800 mm PNC 206308
- Back handrail 1200 mm PNC 206309
- Flue condenser for 1/2 module, 120 mm diameter PNC 206310
- Wok pan support for open burners (700/900) PNC 206363
- Kit town gas nozzles (G150) for 900 gas boiling top PNC 206384
- Kit G.25.3 (NI) gas nozzles for 900 top gas cookers PNC 206457
- Side handrail-right/left hand (900XP) PNC 216044
- Frontal handrail, 400mm PNC 216046
- Frontal handrail, 800mm PNC 216047
- Frontal handrail, 1200mm PNC 216049
- Frontal handrail, 1600mm PNC 216050
- Large handrail - portioning shelf, 400mm PNC 216185
- Large handrail - portioning shelf, 800mm PNC 216186
- 2 side covering panels for top appliances PNC 216278
- Pressure regulator for gas units PNC 927225

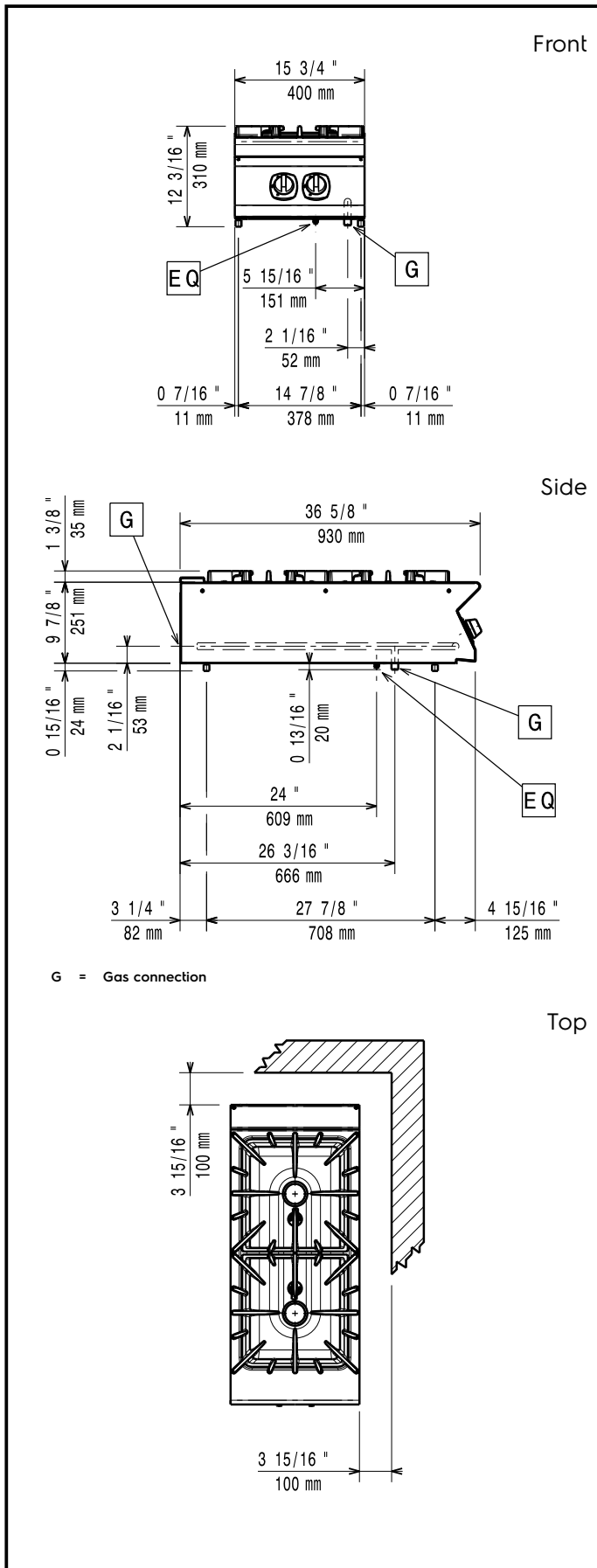

Gas

Gas Power:	
391640 (E9AAQAAOMC)	20 kW
Standard gas delivery:	Natural Gas G20 (20mbar)
Gas Type Option:	LPG; Natural Gas
Gas Inlet:	1/2"

Key Information:

Front Burners Power:	10 - kW
Back Burners Power:	10 - 0 kW
Back Burners Dimension - mm	Ø 100
Front Burners Dimension - mm	Ø 100
External dimensions, Width:	400 mm
External dimensions, Depth:	930 mm
External dimensions, Height:	250 mm
Net weight:	38 kg
Shipping weight:	47 kg
Shipping height:	530 mm
Shipping width:	1020 mm
Shipping depth:	470 mm
Shipping volume:	0.25 m ³

If appliance is set up or next to or against temperature sensitive furniture or similar, a safety gap of approximately 150 mm should be maintained or some form of heat insulation fitted.

Certification group: N9CG