



## Modular Cooking Range Line 900XP 6-Burner Gas Range 10 kW on Gas Oven with Cupboard

ITEM # \_\_\_\_\_

MODEL # \_\_\_\_\_

NAME # \_\_\_\_\_

SIS # \_\_\_\_\_

AIA # \_\_\_\_\_



391014 (E9GCGL6C1M)

6-Burner (10 kW each) gas  
Range on gas Oven (8,5  
kW) with Cupboard

### Short Form Specification

#### Item No.

To be installed on stainless steel feet with height adjustment up to 50 mm. High efficiency flower flame burners with continuous power regulation and optimized combustion. Flame failure device as standard on burners to protect against accidental extinguishing. Oven chamber with 3 levels of runners to accommodate 2/1 GN shelves (2 steam pans). Ribbed, cast-iron oven base plate. Exterior panels of unit in stainless steel with Scotch Brite finish. Pan supports in heavy duty cast iron. Extra strength work top in heavy duty 2 mm stainless steel. Right-angled side edges to allow flush-fitting junction between units.

### Main Features

- Unit to be mounted on stainless steel feet with height adjustment up to 50 mm. Unit can be easily mounted on cantilever systems.
- The six 10 kW high efficiency burners are available in 100 mm diameter with continuous power regulation from 2.2 kW to 10 kW.
- Cupboard compartment for storage of pots, pans, sheet pans etc.
- Gas appliance supplied for use with natural or LPG gas, conversion jets supplied as standard.
- Large sized pan support in cast iron (stainless steel as option) with long center fins to allow the use of the largest down to the smallest pans.
- Burners with optimized combustion.
- Flame failure device on each burner protects against gas leakage when accidental extinguishing of the flame occurs.
- Protected pilot light.
- Base compartment consists of a gas heated standard oven with stainless steel burners and self stabilizing flame positioned beneath the base plate. Oven chamber to have 3 levels of runners to accommodate 2/1 GN shelves (2 steam pans) and ribbed cast iron base plate.
- Oven thermostat adjustable from 120 °C to 280 °C.
- 40 mm thick oven door for heat insulation.
- The special design of the control knob system guarantees against water infiltration.
- IPX5 water protection.
- Control knobs provide smooth, continuous rotation from min to max power level.

### Construction

- Unit is 930 mm deep to give a larger working surface area.
- All exterior panels in Stainless Steel with Scotch Brite finishing.
- AISI 304 stainless steel worktop, 2mm thick.
- Model has right-angled side edges to allow flush fitting joints between units, eliminating gaps and possible dirt traps.

### Included Accessories

- 1 of GN2/1 chrome grid for static oven PNC 164250
- 1 of Door for open base cupboard PNC 206350

### Optional Accessories

- GN2/1 chrome grid for static oven PNC 164250
- Junction sealing kit PNC 206086

APPROVAL: \_\_\_\_\_



Experience the Excellence  
[www.electroluxprofessional.com](http://www.electroluxprofessional.com)

• Draught diverter, 150 mm diameter	PNC 206132	<input type="checkbox"/>	• Chimney grid net, 400mm (700XP/900)	PNC 206400	<input type="checkbox"/>
• Matching ring for flue condenser, 150 mm diameter	PNC 206133	<input type="checkbox"/>	• Kit G.25.3 (NI) gas nozzles for 900 freestanding gas cookers on oven	PNC 206458	<input type="checkbox"/>
• Kit 4 wheels - 2 swivelling with brake - it is mandatory to install Base support and wheels	PNC 206135	<input type="checkbox"/>	• Side handrail-right/left hand (900XP)	PNC 216044	<input type="checkbox"/>
• Flanged feet kit	PNC 206136	<input type="checkbox"/>	• Frontal handrail, 1200mm	PNC 216049	<input type="checkbox"/>
• 2 supports runners for open base cupboard 400mm for GN1/1	PNC 206145	<input type="checkbox"/>	• Frontal handrail, 1600mm	PNC 216050	<input type="checkbox"/>
• Frontal kicking strip for concrete installation, 1200mm	PNC 206151	<input type="checkbox"/>	• 2 side covering panels for free standing appliances	PNC 216134	<input type="checkbox"/>
• Frontal kicking strip for concrete installation, 1600mm	PNC 206152	<input type="checkbox"/>	• Large handrail - portioning shelf, 400mm	PNC 216185	<input type="checkbox"/>
• Pair of side kicking strips for concrete installation	PNC 206157	<input type="checkbox"/>	• Large handrail - portioning shelf, 800mm	PNC 216186	<input type="checkbox"/>
• Single burner smooth plate for direct cooking - fits frontal burners only	PNC 206171	<input type="checkbox"/>	• Pressure regulator for gas units	PNC 927225	<input type="checkbox"/>
• Single burner ribbed plate for direct cooking - fits frontal burners only	PNC 206172	<input type="checkbox"/>			
• Frontal kicking strip, 1200mm (not for refr-freezer base)	PNC 206178	<input type="checkbox"/>			
• Frontal kicking strip, 1600mm (not for refr-freezer base)	PNC 206179	<input type="checkbox"/>			
• Pair of side kicking strips (not for refr-freezer base)	PNC 206180	<input type="checkbox"/>			
• 2 panels for service duct for single installation	PNC 206181	<input type="checkbox"/>			
• 2 panels for service duct for back to back installation	PNC 206202	<input type="checkbox"/>			
• Kit 4 feet for concrete installation (not for 900 line free standing grill)	PNC 206210	<input type="checkbox"/>			
• Flue condenser for 1 module, 150 mm diameter	PNC 206246	<input type="checkbox"/>			
• Electric heating kit for cupboards	PNC 206259	<input type="checkbox"/>			
• Water column with swivel arm (water column extension not included)	PNC 206289	<input type="checkbox"/>			
• Water column extension for 900 line	PNC 206290	<input type="checkbox"/>			
• Stainless steel double grid for 2 burners	PNC 206298	<input type="checkbox"/>			
• Chimney upstand, 1200mm	PNC 206306	<input type="checkbox"/>			
• Back handrail 1200 mm	PNC 206309	<input type="checkbox"/>			
• Door for open base cupboard	PNC 206350	<input type="checkbox"/>			
• Wok pan support for open burners (700/900)	PNC 206363	<input type="checkbox"/>			
• Base support for feet or wheels - 1200mm (700/900)	PNC 206368	<input type="checkbox"/>			
• Base support for feet or wheels - 1600mm (700/900)	PNC 206369	<input type="checkbox"/>			
• Base support for feet or wheels - 2000mm (700/900)	PNC 206370	<input type="checkbox"/>			
• Base support for feet or wheels (lateral) for 23lt fryers, pasta cookers and refrigerated bases (900XP)	PNC 206372	<input type="checkbox"/>			
• Rear paneling - 1200mm (700/900)	PNC 206376	<input type="checkbox"/>			
• Kit town gas nozzles (G150) for 900 gas ranges on gas oven	PNC 206385	<input type="checkbox"/>			

Front

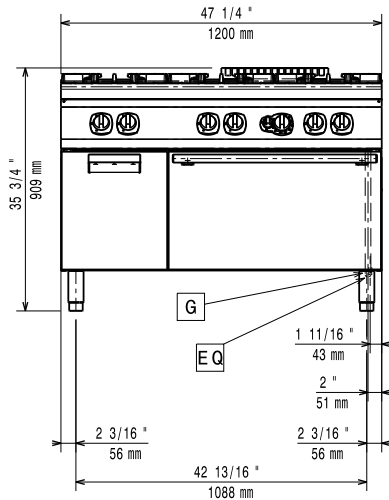

Side

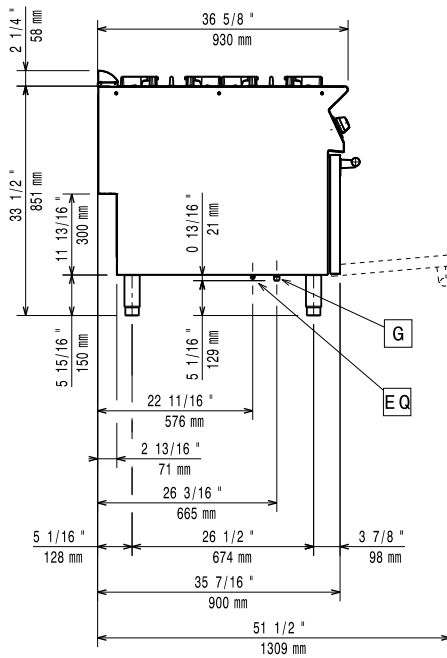

G = Gas connection

Top

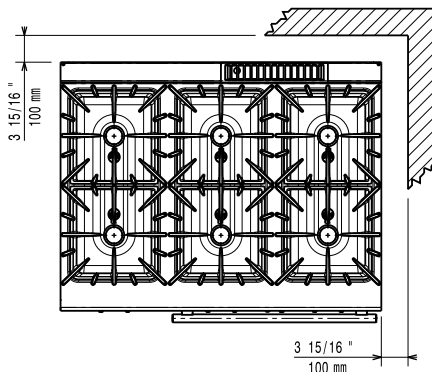

## Gas

<b>Gas Power:</b>	
391014 (E9GCGL6C1M)	68.5 kW
<b>Standard gas delivery:</b>	Natural Gas G20 (20mbar)
<b>Gas Type Option:</b>	LPG; Natural Gas
<b>Gas Inlet:</b>	1/2"

## Key Information:

<b>Front Burners Power:</b>	10 - 10 kW
<b>Back Burners Power:</b>	10 - 10 kW
<b>Middle Burners Power:</b>	10 - 0/10 - 0 kW
<b>Back Burners Dimension - mm</b>	Ø 100 Ø 100
<b>Front Burners Dimension - mm</b>	Ø 100 Ø 100
<b>Middle Burners Dimension - mm</b>	Ø 100 Ø 100
<b>Oven working Temperature:</b>	120 °C MIN; 280 °C MAX

<b>Oven Cavity Dimensions (width):</b>	575 mm
<b>Oven Cavity Dimensions (height):</b>	300 mm
<b>Oven Cavity Dimensions (depth):</b>	700 mm
<b>External dimensions, Width:</b>	1200 mm
<b>External dimensions, Depth:</b>	930 mm
<b>External dimensions, Height:</b>	850 mm
<b>Net weight:</b>	164 kg
<b>Shipping weight:</b>	180 kg
<b>Shipping height:</b>	1080 mm
<b>Shipping width:</b>	1020 mm
<b>Shipping depth:</b>	1260 mm
<b>Shipping volume:</b>	1.39 m <sup>3</sup>
<b>Certification group:</b>	N9CG

If appliance is set up or next to or against temperature sensitive furniture or similar, a safety gap of approximately 150 mm should be maintained or some form of heat insulation fitted.