



Modular Cooking Range Line 900XP 4-Hot Plates Electric Boiling Top

ITEM # _____

MODEL # _____

NAME # _____

SIS # _____

AIA # _____



391040 (E9ECEH4Q00)

4-Hot Square Plates (4 kW each) electric Boiling Top

391166 (E9ECEH4Q0N)

4-Hot Plate (4 kW each) electric Boiling Top

Short Form Specification

Item No. _____

To be installed on open base installations, bridging supports or cantilever systems. Four 4 kW square cast-iron hot plates hermetically sealed to the one-piece top. Exterior panels of unit in stainless steel with Scotch Brite finish. Extra strength work top in heavy duty 2 mm stainless steel. Right-angled side edges to allow flush-fitting junction between units.

Main Features

- Unit to be mounted on open base cupboards, bridging supports or cantilever systems.
- The four 4kW cast-iron plates are hermetically sealed to the one-piece top. Hot plates with a power of 4kW for each plate.
- The special design of the control knob system guarantees against water infiltration.
- IPX5 water protection.
- Top configuration allows installation on ambient base only (not possible to install on refrigerated nor freezer base).
- Suitable for countertop installation.

Construction

- Unit is 930 mm deep to give a larger working surface area.
- All exterior panels in Stainless Steel with Scotch Brite finishing.
- AISI 304 stainless steel worktop, 2mm thick.
- Model has right-angled side edges to allow flush fitting joints between units, eliminating gaps and possible dirt traps.

APPROVAL: _____



Experience the Excellence
www.electroluxprofessional.com

Optional Accessories

- GN2/1 chrome grid for static oven (only for 391166) PNC 164250
- Pair of cast iron plate bars for electric cooking top PNC 206056
- Junction sealing kit PNC 206086
- Support for bridge type installation, 800mm PNC 206137
- Support for bridge type installation, 1000mm PNC 206138
- Support for bridge type installation, 1200mm PNC 206139
- Support for bridge type installation, 1400mm PNC 206140
- Support for bridge type installation, 1600mm PNC 206141
- Water column with swivel arm (water column extension not included) PNC 206289
- Water column extension for 900 line PNC 206290
- Chimney upstand, 800mm PNC 206304
- Back handrail 800 mm PNC 206308
- Back handrail 1200 mm PNC 206309
- Support frame for 2 pasta cooker basket (900XP) (only for 391040) PNC 206395
- Chimney grid net, 400mm (700XP/900) PNC 206400
- Side handrail-right/left hand (900XP) PNC 216044
- Frontal handrail, 800mm PNC 216047
- Frontal handrail, 1200mm PNC 216049
- Frontal handrail, 1600mm PNC 216050
- Large handrail - portioning shelf, 400mm (only for 391166) PNC 216185
- Large handrail - portioning shelf, 800mm PNC 216186
- 2 side covering panels for top appliances PNC 216278

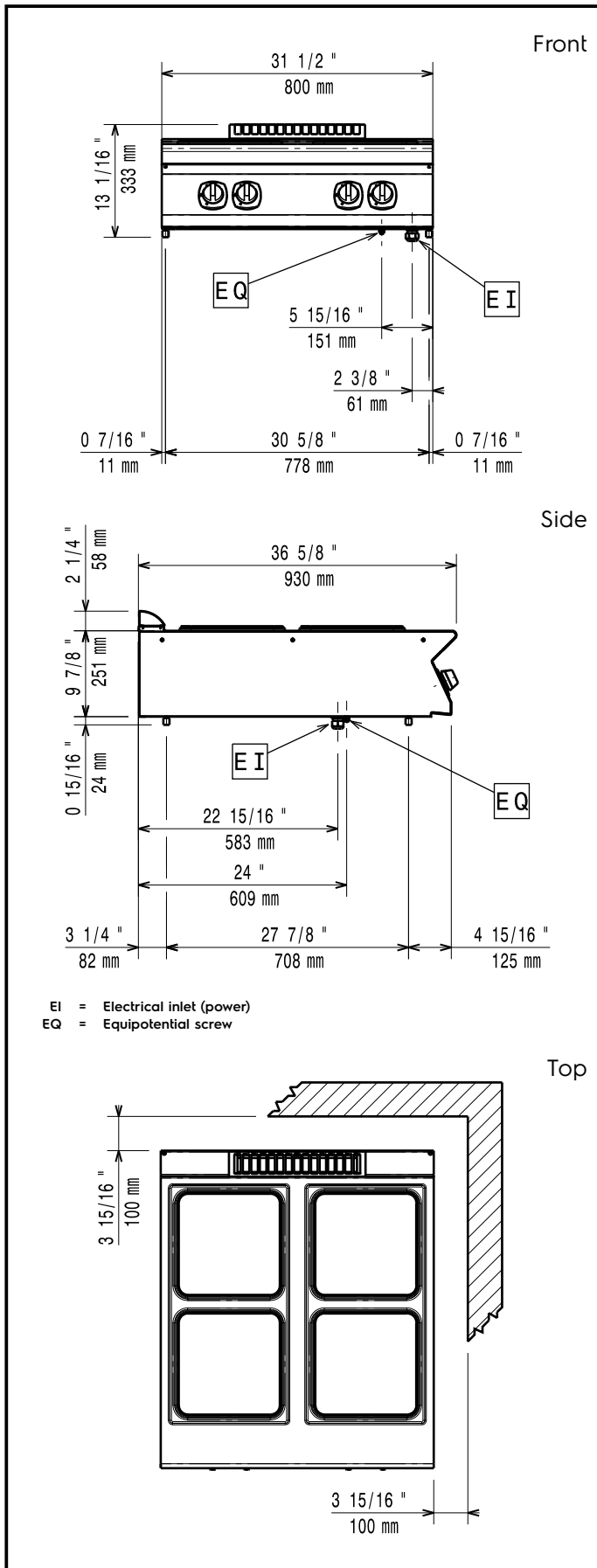

Electric

Supply voltage:

391040 (E9ECEH4Q00)

380-400 V/3N ph/50/60 Hz

391166 (E9ECEH4Q0N)

230 V/3 ph/50/60 Hz

Total Watts:

16 kW

Predisposed for:

391040 (E9ECEH4Q00)

380-400V 3N- 50/60Hz
15-16kW

Key Information:

Front Plates Power:

4 - 4 kW

Back Plates Power:

4 - 4 kW

Front Plates dimensions:

300x300 300x300

Back Plates dimensions:

300x300 300x300

External dimensions, Width:

800 mm

External dimensions, Depth:

930 mm

External dimensions, Height:

250 mm

Net weight:

391040 (E9ECEH4Q00)

60 kg

391166 (E9ECEH4Q0N)

69 kg

Shipping weight:

72 kg

Shipping height:

530 mm

Shipping width:

391040 (E9ECEH4Q00)

1020 mm

391166 (E9ECEH4Q0N)

1010 mm

Shipping depth:

860 mm

Shipping volume:

0.46 m³

If appliance is set up or next to or against temperature sensitive furniture or similar, a safety gap of approximately 150 mm should be maintained or some form of heat insulation fitted.

Certification group:

391040 (E9ECEH4Q00)

EH94T

391166 (E9ECEH4Q0N)

N9CE1