



Electrolux
PROFESSIONAL

**Modular Cooking Range Line
900XP 2 Hot Plate Electric Infrared
Cooking Top Range**

ITEM # _____

MODEL # _____

NAME # _____

SIS # _____

AIA # _____



391044 (E9IRED2000)

2-zone (3,4 kW each)
electric Infrared Cooking
Top

Short Form Specification

Item No. _____

Glass ceramic cooking surface 6 mm thick, with 2 concentric circular heating zones. Infrared top surface with seamless transition between individual heating zones. Body and work top of unit entirely in stainless steel with Scotch Brite finish. Extra strength work top in heavy duty 2 mm stainless steel. Right-angled side edges to allow flush-fitting junction between units.

Main Features

- Ceramic glass top cooking surface with 2 infrared heating zones 6 mm thick.
- The circular concentric heating sections measuring from 180 to 300 mm give uniform heat also to the largest pan.
- The cooking top is sealed to prevent infiltration inside the unit.
- Warning light to indicate residual surface heat.
- Immediate heat transfer from cooking top to pan.
- Low heat dissipation to the kitchen.
- The smooth glass-ceramic surface can be quickly and easily cleaned, thus providing maximum hygiene.
- IPX5 water protection.
- Suitable for countertop installation.

Construction

- Unit is 930 mm deep to give a larger working surface area.
- All exterior panels in Stainless Steel with Scotch Brite finishing.
- AISI 304 stainless steel worktop, 2mm thick.
- Model has right-angled side edges to allow flush fitting joints between units, eliminating gaps and possible dirt traps.

Sustainability

- Energy regulation of each zone.



APPROVAL: _____



Experience the Excellence
www.electroluxprofessional.com

Optional Accessories

- Junction sealing kit PNC 206086
- Support for bridge type installation, 800mm PNC 206137
- Support for bridge type installation, 1000mm PNC 206138
- Support for bridge type installation, 1200mm PNC 206139
- Support for bridge type installation, 1400mm PNC 206140
- Support for bridge type installation, 1600mm PNC 206141
- Support for bridge type installation, 400mm PNC 206154
- Water column with swivel arm (water column extension not included) PNC 206289
- Water column extension for 900 line PNC 206290
- Chimney upstand, 400mm PNC 206303
- Back handrail 800 mm PNC 206308
- Back handrail 1200 mm PNC 206309
- Side handrail-right/left hand (900XP) PNC 216044
- Frontal handrail, 400mm PNC 216046
- Frontal handrail, 800mm PNC 216047
- Frontal handrail, 1200mm PNC 216049
- Frontal handrail, 1600mm PNC 216050
- Large handrail - portioning shelf, 400mm PNC 216185
- Large handrail - portioning shelf, 800mm PNC 216186
- 2 side covering panels for top appliances PNC 216278

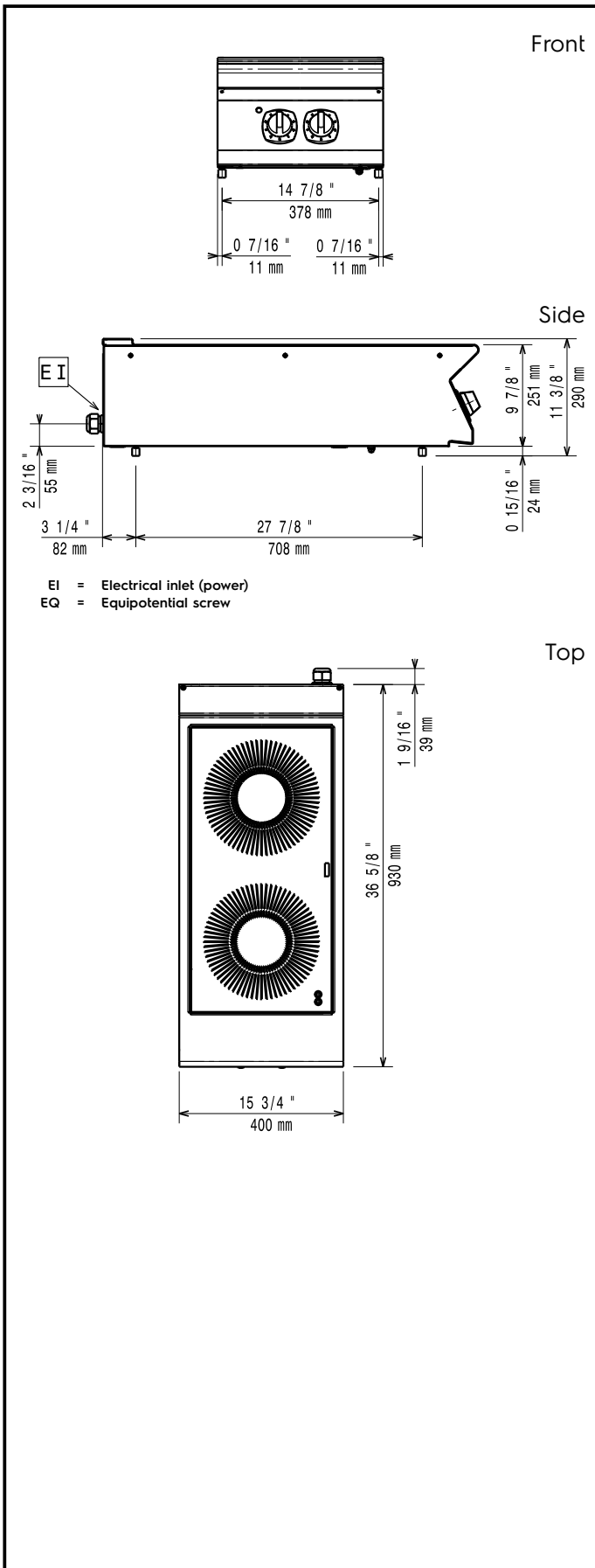

Electric

Supply voltage:

380-400 V/3N ph/50/60 Hz

391044 (E9IRED2000)

Total Watts:

6.8 kW

380-400V 3N~ 50/60Hz

Predisposed for:

6-6,8kW

Key Information:

Front Plates Power:

3.4 - 0 kW

Back Plates Power:

3.4 - kW

Front Plates dimensions:

Ø 300

Back Plates dimensions:

Ø 300

External dimensions, Width:

400 mm

External dimensions, Depth:

930 mm

External dimensions, Height:

250 mm

Net weight:

24.5 kg

Shipping weight:

35 kg

Shipping height:

520 mm

Shipping width:

460 mm

Shipping depth:

1020 mm

Shipping volume:

0.24 m³

Certification group:

N9CIE

If appliance is set up or next to or against temperature sensitive furniture or similar, a safety gap of approximately 150 mm should be maintained or some form of heat insulation fitted.