



Modular Cooking Range Line 900XP 4 Zone Electric Induction Cooking Top

ITEM # _____

MODEL # _____

NAME # _____

SIS # _____

AIA # _____



391278 (E9INEH4008)

4-zone (5 kW each) electric
Induction Cooking Top

Short Form Specification

Item No. _____

Glass ceramic cooking surface with 4 independently controlled 5 kW induction zones. Induction top surface with seamless transition between individual heating zones. Body and work top of unit entirely in stainless steel with Scotch Brite finish. Extra strength work top in heavy duty 2 mm stainless steel. Right-angled side edges to allow flush-fitting junction between units.

Main Features

- Glass ceramic cooking surface with 4 independently controlled induction zones with a power of 5 kW per zone.
- Almost the entire surface of the ceramic plate can be used without "dead" spots.
- One indicating lamp for each zone located on control console.
- Induction plates endowed with overheating safety device.
- Power to the individual zones can be set with progressive output i.e. fine regulation at the lower and larger progress at the upper levels.
- Low heat dissipation to the kitchen.
- The smooth, glass ceramic plate is not directly heated, so there is no burning on cooking surface.
- IPX5 water protection.
- Pots diameter to be used : min 12cm, max 28 cm in order to obtain maximum heating efficiency.
- Suitable for countertop installation.

Construction

- Unit is 930 mm deep to give a larger working surface area.
- All exterior panels in Stainless Steel with Scotch Brite finishing.
- AISI 304 stainless steel worktop, 2mm thick.
- Model has right-angled side edges to allow flush fitting joints between units, eliminating gaps and possible dirt traps.

Sustainability



- This model is compliant with Swiss Energy Efficiency Ordinance (730.02).

APPROVAL: _____



Experience the Excellence
www.electroluxprofessional.com

Optional Accessories

- Junction sealing kit PNC 206086
- Support for bridge type installation, 800mm PNC 206137
- Support for bridge type installation, 1000mm PNC 206138
- Support for bridge type installation, 1200mm PNC 206139
- Support for bridge type installation, 1400mm PNC 206140
- Support for bridge type installation, 1600mm PNC 206141
- Water column extension for 900 line PNC 206290
- Chimney upstand, 800mm PNC 206304
- Frontal handrail, 1600mm PNC 216050
- 2 side covering panels for top appliances PNC 216278
- Stainless steel universal frying pan with stainless steel handle (diam. 200mm) suitable for induction and all other heating sources PNC 653596
- Universal frying pan with stainless steel handle (diam. 240mm) suitable for induction and all other heating sources PNC 653597
- Universal frying pan with stainless steel handle (diam. 280mm) suitable for induction and all other heating sources PNC 653598

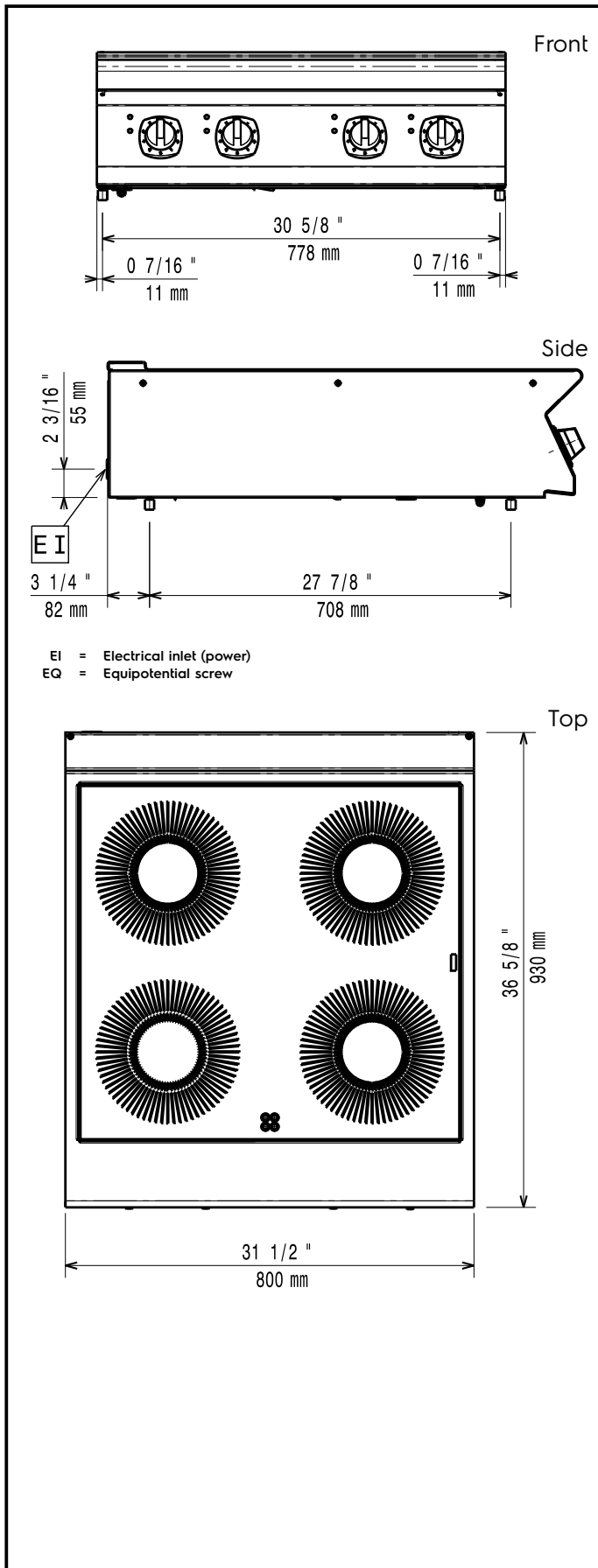

Electric

Supply voltage:	391278 (E9INEH4008)	380-415 V/3 ph/50/60 Hz
Total Watts:		20 kW
		380-415V 3- 50/60Hz 20kW

Predisposed for:

Key Information:

Induction Top Dimensions (width):	800 mm
Induction Top Dimensions (depth):	930 mm
External dimensions, Width:	800 mm
External dimensions, Depth:	930 mm
External dimensions, Height:	250 mm
Net weight:	65 kg
Shipping weight:	76 kg
Shipping height:	540 mm
Shipping width:	1020 mm
Shipping depth:	860 mm
Shipping volume:	0.47 m ³

Induction compatible pots & pans must be used.

Certification group: IH940

If appliance is set up or next to or against temperature sensitive furniture or similar, a safety gap of approximately 150 mm should be maintained or some form of heat insulation fitted.