



Modular Cooking Range Line 900XP Two Wells Electric Fryer 23 liter

ITEM # _____

MODEL # _____

NAME # _____

SIS # _____

AIA # _____



391385 (E9KKGOBAMEA) 23+23-lt electric Fryer with 2 "V" shaped wells (external heating elements) and 4 half size baskets

391338 (E9KKGDBAMEA) 23+23-lt electric Fryer with 2 "V" shaped wells (external heating elements) and 4 half size baskets

Short Form Specification

Item No. _____

High efficiency external infrared heating elements (36kW) with innovative deflectors attached to the outside of the well. Deep drawn V-Shaped wells. Oil drains through a tap into a container positioned under the wells. Height adjustable feet in stainless steel. Exterior panels in stainless steel. Worktop in 20/10, stainless steel. Right-angled side edges eliminate gaps and possible dirt traps between units.

Main Features

- Deep drawn V-Shaped wells.
- Interior of wells with seamlessly laser-welded corners for ease of cleaning.
- External infrared heating elements with innovative deflectors applied to the well for ease of cleaning of the internal well and safe operations.
- Thermostatic regulation of oil temperature up to a maximum of 185 °C.
- Overheat protection thermostat as standard on all units.
- All major compartments located in front of unit for ease of maintenance.
- IPX5 water resistance certification.
- The special design of the control knob system guarantees against water infiltration.
- Supplied as standard with 4 half size baskets and 1 right and left side doors for cupboard.
- Optional portable oil quality monitoring tool (code 9B8081) for efficient oil management.

Construction

- Unit is 930 mm deep to give a larger working surface area.
- All exterior panels in Stainless Steel with Scotch Brite finishing.
- Model has right-angled side edges to allow flush fitting joints between units, eliminating gaps and possible dirt traps.
- Unit delivered with four 50 mm legs in stainless steel as standard.

Sustainability

- This model is compliant with Swiss Energy Efficiency Ordinance (730.02).



APPROVAL: _____



Included Accessories

- 2 of Door for open base cupboard PNC 206350
- 2 of 2 half size baskets for 18/23 lt fryers PNC 927223

Optional Accessories

- Stainless steel oil filter for 23-litre fryer to remove particles of grease and food residuals) - 900XP PNC 200086
- Lid for oil container for 23 l Fryers (only for 391385) PNC 200171
- Junction sealing kit PNC 206086
- Kit 4 wheels - 2 swivelling with brake - it is mandatory to install Base support and wheels PNC 206135
- Flanged feet kit PNC 206136
- Frontal kicking strip for concrete installation, 800mm (only for 391385) PNC 206148
- Frontal kicking strip for concrete installation, 1000mm (only for 391385) PNC 206150
- Frontal kicking strip for concrete installation, 1200mm (only for 391385) PNC 206151
- Frontal kicking strip for concrete installation, 1600mm (only for 391385) PNC 206152
- Pair of side kicking strips (not for refr-freezer base) PNC 206180
- 2 panels for service duct for single installation (only for 391385) PNC 206181
- Hygienic lid for 23lt fryers PNC 206201
- 2 panels for service duct for back to back installation (only for 391385) PNC 206202
- Frontal kicking strip for 23lt fryers in two parts PNC 206203
- Extension pipe for oil drainage for fryers PNC 206209
- Kit 4 feet for concrete installation (not for 900 line free standing grill) (only for 391385) PNC 206210
- Chimney upstand, 800mm PNC 206304
- Back handrail 800 mm (only for 391385) PNC 206308
- Back handrail 1200 mm (only for 391385) PNC 206309
- Door for open base cupboard PNC 206350
- Base support for feet or wheels (lateral) for 23lt fryers, pasta cookers and refrigerated bases (900XP) PNC 206372
- Rear paneling - 800mm (700/900) (only for 391385) PNC 206374
- Rear paneling - 1000mm (700/900) (only for 391385) PNC 206375
- Rear paneling - 1200mm (700/900) (only for 391385) PNC 206376
- Chimney grid net, 400mm (700XP/900) PNC 206400
- 2 side covering panels for free standing appliances PNC 216134
- Sediment collection tray for 23-litre fryer (to be put in the well) PNC 921023
- 2 half size baskets for 18/23 lt fryers PNC 927223
- 1 full size basket for 18/23 lt fryers PNC 927226
- Unclogging rod for 23lt fryers drainage pipe PNC 927227
- Deflector for floured products for 23lt fryers PNC 960645

Front

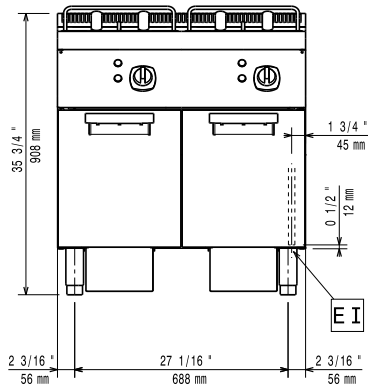

Side

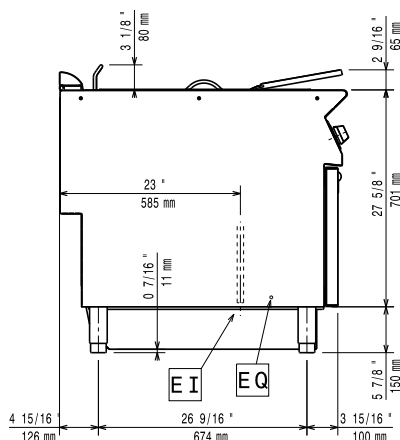

EI = Electrical inlet (power)
 EQ = Equipotential screw

Top

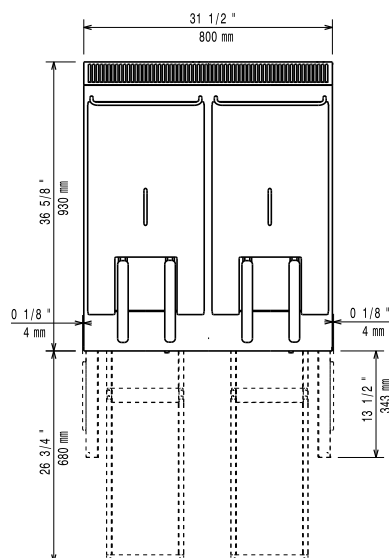

Electric

Supply voltage:

391385 (E9KKG0BAMEA) 415-430 V/3N ph/50/60 Hz
 380-400 V/3N ph/50/60 Hz

391338 (E9KKGDBAMEA)

Total Watts:

391385 (E9KKG0BAMEA) 34.4 kW
 391338 (E9KKGDBAMEA) 36 kW

Key Information:

Usable well dimensions

(width): 340 mm

Usable well dimensions

(height): 575 mm

Usable well dimensions

(depth): 400 mm

Well capacity:

21 lt MIN; 23 lt MAX

Performance*:

391385 (E9KKG0BAMEA) 70.8 kg\hr

391338 (E9KKGDBAMEA) 75 kg\hr

Thermostat Range:

105 °C MIN; 185 °C MAX

Net weight:

115 kg

Shipping weight:

391385 (E9KKG0BAMEA) 120 kg

391338 (E9KKGDBAMEA) 125 kg

Shipping height:

1080 mm

Shipping width:

1020 mm

Shipping depth:

391385 (E9KKG0BAMEA) 860 mm

391338 (E9KKGDBAMEA) 880 mm

Shipping volume:

391385 (E9KKG0BAMEA) 0.95 m³

391338 (E9KKGDBAMEA) 0.97 m³

*Based on: ASTM F1361-Deep fat fryers

Certification group:

EFE92M23