



Modular Cooking Range Line 900XP 2 Drawer Refrigerated Base

ITEM # _____

MODEL # _____

NAME # _____

SIS # _____

AIA # _____

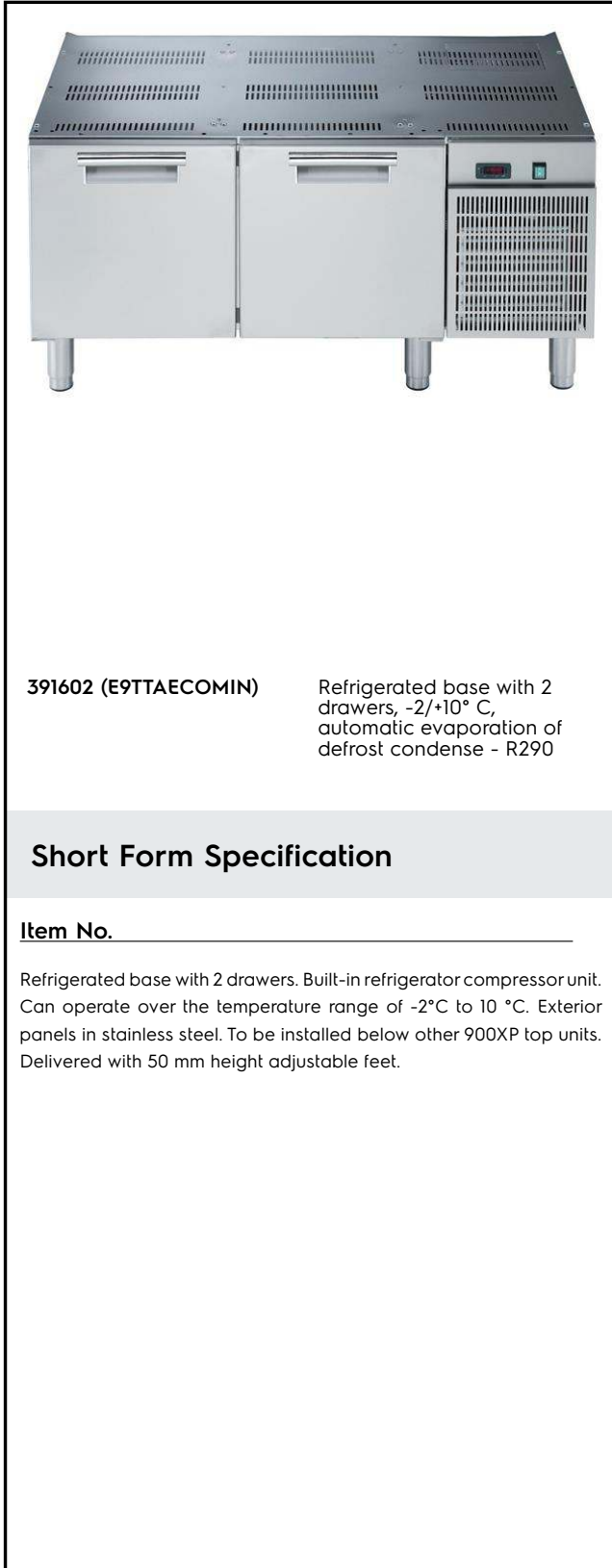

391602 (E9TTAECOMIN)

Refrigerated base with 2 drawers, -2/+10° C, automatic evaporation of defrost condense - R290

Short Form Specification

Item No. _____

Refrigerated base with 2 drawers. Built-in refrigerator compressor unit. Can operate over the temperature range of -2°C to 10 °C. Exterior panels in stainless steel. To be installed below other 900XP top units. Delivered with 50 mm height adjustable feet.

Main Features

- Unit can be easily installed below other 900 line top models.
- Adjustable temperature range from -2 °C to +10 °C to suit meat, fish and dairy storage requirements.
- Forced air circulation for rapid cooling and an even temperature distribution.
- Defrosting and automatic evaporation of condense drain: the condense is automatically evaporated thanks to the electric resistance in the condense drain container.
- GN compliant.
- Designed for modular installation into the cooking block.

Construction

- Constructed in Stainless steel with Scotch Brite finish to meet the highest hygiene standards.
- Built-in compressor to suit operating conditions.
- Access to all components from the front.
- Unit delivered with 150 mm height adjustable feet in Stainless steel. Feet can be extended up to 250 mm.

Sustainability



- CFC and HCFC free (highly ecological refrigerant type: R290).

Optional Accessories

- Flanged feet kit PNC 206136
- Frontal kicking strip for concrete installation, 1200mm PNC 206151
- Frontal kicking strip, 1200mm (not for refr-freezer base) PNC 206178
- Rear paneling - 1200mm (700/900) PNC 206376
- Kit 3 base support for wheels PNC 206430
- Kit 6 wheels - 3 swivelling with brake PNC 206432

APPROVAL: _____



Experience the Excellence
www.electroluxprofessional.com

Front

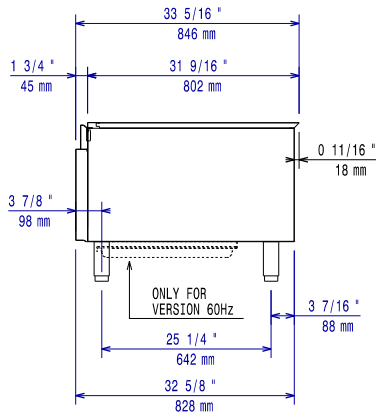

Side

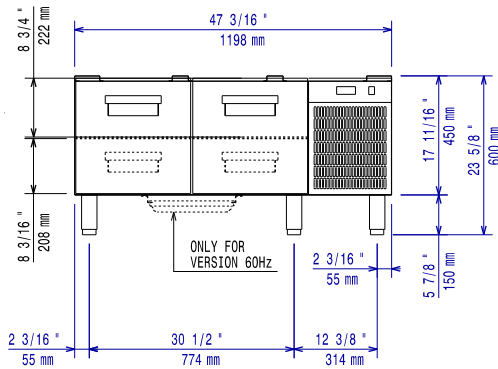

D = Drain
 EI = Electrical inlet (power)

Top

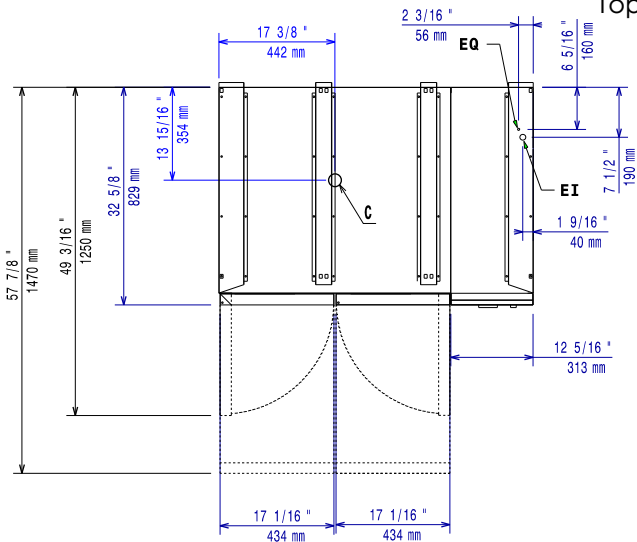

Electric

Supply voltage:	391602 (E9TTAECOMIN)	220-230 V/1N ph/50 Hz
Electrical power max.:		0.44 kW
Total Watts:		0.44 kW

Key Information:

Gross capacity:	225 lt
External dimensions, Width:	1200 mm
External dimensions, Depth:	830 mm
External dimensions, Height:	600 mm
Net weight:	114 kg
Shipping weight:	123 kg
Shipping height:	830 mm
Shipping width:	1060 mm
Shipping depth:	1300 mm
Shipping volume:	1.14 m ³

Refrigeration Data

Compressor power:

Sustainability

Refrigerant type:	R290
Refrigerant weight:	85 g