



## Modular Cooking Range Line 900XP 2 Drawer Ref-freezer Base (R290)

ITEM # \_\_\_\_\_

MODEL # \_\_\_\_\_

NAME # \_\_\_\_\_

SIS # \_\_\_\_\_

AIA # \_\_\_\_\_



729631 (E9BAPL00MP)

HP Ref-Freezer Base with 2 drawers, -22/+8° C - R290

### Short Form Specification

**Item No.** \_\_\_\_\_

Refrigerated base with 2 drawers, able to operate both as refrigerator or freezer, with temperature range from -22°C to +8°C. Each drawer can accommodate one GN 2/1 container. The heavy duty drawer guides are equipped with a safety stop mechanism and are removable for cleaning, as well as the magnetic snap-in gaskets. CFC and HCFC free, highly ecological refrigerant type: R290 (ecological gas in foam: cyclopentane). Hydrocarbon refrigerant gas R290 for the lowest environmental impact (GWP=3), to reduce green house and ozone depletion effects. Large digital white-digit soft touch display. Stainless steel exterior panels and heavy duty tubular drawer handles. To be installed below other 900XP top units. Delivered with 100 mm height adjustable feet. IPX3 water resistance certification. Connectivity ready.

### Main Features

- Exclusive IcyHot installation: combine 1200 mm PowerGrillsHP or NitroChrome3 Fry Top HP with the dual temperature ref/freezer base, obtaining a single appliance with higher productivity and more efficient cooking and storage operations.
- Two Drawer Refrigerated/Freezer Base with built-in compressor unit.
- Unit able to operate both as refrigerator or as freezer, with temperature range from -22°C to +8°C.
- Suitable for use in ambient temperatures of up to 40 °C.
- Designed for modular installation into the cooking block.
- All major components may be easily accessed from the front.
- Each drawer to accommodate one GN 2/1 container max 150 mm high.
- Magnetic snap-in drawer gaskets are removable for cleaning.
- Forced air circulation for rapid cooling and an even temperature distribution.
- Unit may be installed on castors.
- Connectivity ready for real time access to connected appliances from remote and data monitoring (requires optional accessory).
- Perforated top surface and bottom plate for a better air circulation.
- Heavy-duty stainless steel tubular drawer handles.

### Construction

- Large digital white-digit display with soft touch buttons.
- Supplied with 100 mm height adjustable feet.
- Constructed in Stainless steel with Scotch Brite finish to meet the highest hygiene standards.
- Built-in compressor to suit operating conditions.
- IPX3 protected.

### Sustainability

- CFC and HCFC free, highly ecological refrigerant type: R290 (ecological gas in foam: cyclopentane). Hydrocarbon refrigerant gas R290 for the lowest environmental



APPROVAL: \_\_\_\_\_



Experience the Excellence  
[www.electroluxprofessional.com](http://www.electroluxprofessional.com)

impact (GWP=3), to reduce green house and ozone depletion effects.

### Optional Accessories

- 4 wheels - 2 with brake for re-Freezer Base, H=145mm - to be used only for standalone installation PNC 880123
- Pair of side kicking strips for refr-freezer base PNC 880221
- 4 wheels, 2 with bakes, for refrigerated and Freezer Base, H=125mm PNC 880234
- Support GN container for refrigerated/freezer base PNC 880249
- Frontal kicking strip for freezer/refrigerated base PNC 880336
- Ethernet connector for IR33 (CAREL) Refrigerated Cabinets and Counters PNC 881299

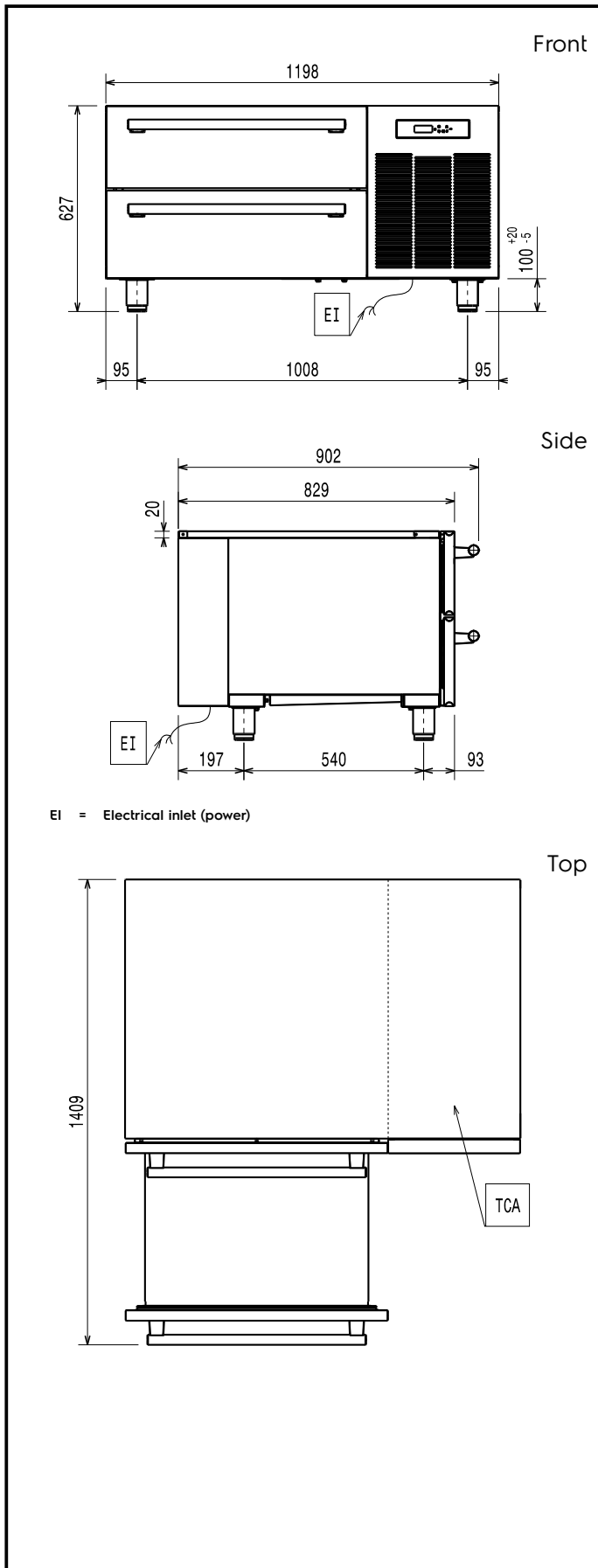

## Electric

<b>Supply voltage:</b>	729631 (E9BAPL00MP)	220-240 V/1 ph/50 Hz
<b>Electrical power max.:</b>		0.55 kW
<b>Total Watts:</b>		0.55 kW

## Key Information:

<b>External dimensions, Width:</b>	1198 mm
<b>External dimensions, Depth:</b>	902 mm
<b>External dimensions, Height:</b>	627 mm
<b>Net weight:</b>	118 kg
<b>Shipping weight:</b>	161 kg
<b>Shipping height:</b>	940 mm
<b>Shipping width:</b>	1050 mm
<b>Shipping depth:</b>	1400 mm
<b>Shipping volume:</b>	1.38 m <sup>3</sup>

## Refrigeration Data

<b>Compressor power:</b>	3/4 hp
--------------------------	--------

## Sustainability

<b>Current consumption:</b>	4.2 Amps
<b>Refrigerant type:</b>	R290
<b>Refrigeration power:</b>	0 W
<b>Refrigerant weight:</b>	120 g