



**Electrolux**  
PROFESSIONAL

**Modular Cooking Range Line  
700XP 400mm Electric Fry Top,  
Smooth Polished Chrome Plate**

ITEM # \_\_\_\_\_

MODEL # \_\_\_\_\_

NAME # \_\_\_\_\_

SIS # \_\_\_\_\_

AIA # \_\_\_\_\_



371193 (E7FTEDCS10)

Half module electric Fry Top with smooth polished chrome cooking Plate, thermostatic control

**Short Form Specification**

Item No. \_\_\_\_\_

To be installed on open base installations or bridging supports. Smooth polished chrome cooking surface. Temperature range from 120°C to 280°C. Removable drawer below the cooking surface for the collection of grease and fat. Exterior panels in stainless steel with Scotch Brite finish. One piece pressed work top in 1.5 mm thick stainless steel. Right-angled side edges to allow flush-fitting junction between units.

**Main Features**

- Unit to be mounted on open base cupboards, bridging supports or cantilever systems.
- Large drain hole on cooking surface permits the draining of fat into large 1 liter collector placed under the cooking surface.
- Large grease collection container available as optional accessory to be installed under top units over open base cupboard.
- Safety thermostat and thermostatic control.
- Stainless steel high splash guard on the rear and sides of cooking surface. Splash guard can be easily removed for cleaning.
- IPx4 water protection.
- Frontal simmering zone.
- Temperature range from 120° up to 280°C.
- Polished chromium surface avoids the mixing of flavors when passing from one type of food to another.
- Cooking surface 12mm thick polished chrome for optimum grilling results and ease of use.
- Infrared heating elements mounted below the cooking surface.
- Suitable for countertop installation.

**Construction**

- All exterior panels in Stainless Steel with Scotch Brite finishing.
- One piece pressed 1.5 mm work top in Stainless steel.
- Model has right-angled side edges to allow flush fitting joints between units, eliminating gaps and possible dirt traps.
- Cooking surface completely smooth.

APPROVAL: \_\_\_\_\_



Experience the Excellence  
www.electroluxprofessional.com

**Included Accessories**

- 1 of Scraper for smooth plate fry tops PNC 164255

**Optional Accessories**

- Scraper for smooth plate fry tops PNC 164255
- Junction sealing kit PNC 206086
- Support for bridge type installation, 800mm PNC 206137
- Support for bridge type installation, 1000mm PNC 206138
- Support for bridge type installation, 1200mm PNC 206139
- Support for bridge type installation, 1400mm PNC 206140
- Support for bridge type installation, 1600mm PNC 206141
- Support for bridge type installation, 400mm PNC 206154
- Kit 4 feet for concrete installation (not for 900 line free standing grill) PNC 206210
- Chimney upstand, 400mm PNC 206303
- Right and left side handrails PNC 206307
- Back handrail 800 mm PNC 206308
- Grease/oil kit container for 700 line frytops (half and module) and 900 line frytops (module) PNC 206346
- Chimney grid net, 400mm (700XP/900) PNC 206400
- Cloche for fry tops PNC 206455
- Frontal handrail, 400mm PNC 216046
- Frontal handrail, 800mm PNC 216047
- Frontal handrail, 1200mm PNC 216049
- Frontal handrail, 1600mm PNC 216050
- Large handrail - portioning shelf, 400mm PNC 216185
- Large handrail - portioning shelf, 800mm PNC 216186
- 2 side covering panels for top appliances PNC 216277

Front

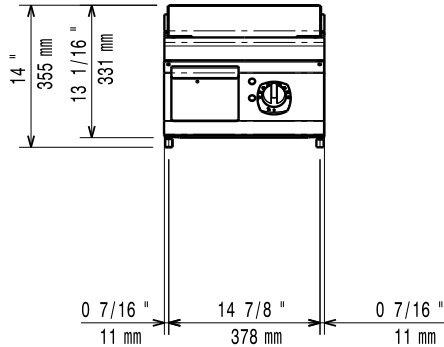

Side

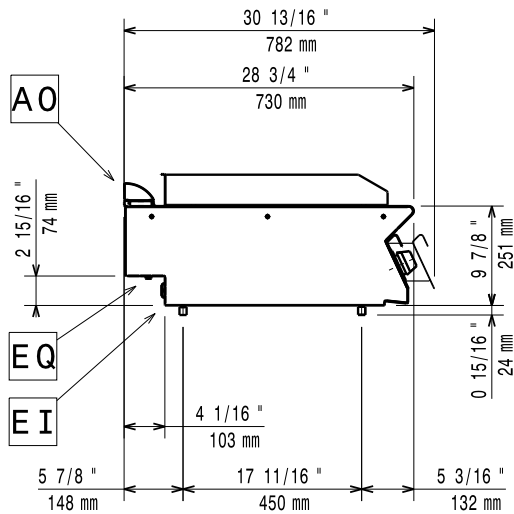

EI = Electrical inlet (power)  
 EQ = Equipotential screw

Top

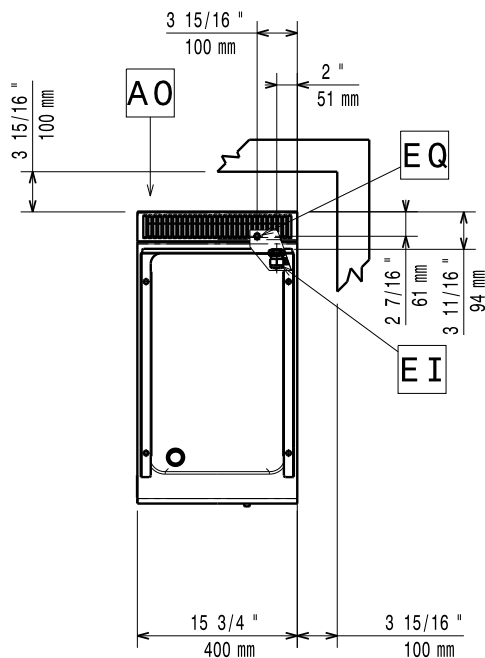

### Electric

#### Supply voltage:

371193 (E7FTEDCSI0) 400 V/3 ph/50/60 Hz

#### Electrical power max.:

4.2 kW

#### Total Watts:

4.2 kW

#### Predisposed for:

380-400V 3~ 50/60Hz  
 3.8-4.2kW

### Key Information:

Cooking surface width: 330 mm

Cooking surface depth: 540 mm

Working Temperature MIN: 120 °C

Working Temperature MAX: 280 °C

External dimensions, Width: 400 mm

External dimensions, Depth: 730 mm

External dimensions, Height: 250 mm

Net weight: 40 kg

Shipping weight: 41 kg

Shipping height: 530 mm

Shipping width: 460 mm

Shipping depth: 820 mm

Shipping volume: 0.2 m<sup>3</sup>

If appliance is set up or next to or against temperature sensitive furniture or similar, a safety gap of approximately 150 mm should be maintained or some form of heat insulation fitted.

#### Certification group:

EFT71