

Modular Cooking Range Line 700XP 4 Zone Electric Infrared Cooking Top Range on Electric Oven

ITEM # _____

MODEL # _____

NAME # _____

SIS # _____

AIA # _____

371026 (E7IREH40E0)

 4-zone (2,2 kW each)
 infrared cooking Range on
 electric Oven (6 kW)

Short Form Specification

Item No. _____

Ceramic glass top cooking surface 6 mm thick, lying flush to the stainless steel frame for smooth pan movement and easier cleaning. Completely sealed infrared cooking top surface to prevent liquid infiltration. Electric oven with switch to control top and bottom heating elements. Stainless steel oven chamber with 3 levels of runners to accommodate 2/1 GN shelves (2 steam pans) and ribbed oven base plate. Exterior panels in stainless steel with Scotch Brite finish. One piece pressed work top in 1.5 mm thick stainless steel. Right-angled side edges to allow flush-fitting junction between units.

Main Features

- Ceramic glass top cooking surface with 4 infrared heating zones 6 mm thick.
- The circular concentric heating sections measuring 230 mm give uniform heat also to the largest pan.
- The cooking top is sealed to prevent infiltration inside the unit.
- Warning light to indicate residual surface heat.
- Immediate heat transfer from cooking top to pan.
- Low heat dissipation to the kitchen.
- Heating via ultra high powered heating elements.
- The smooth glass-ceramic surface can be quickly and easily cleaned, thus providing maximum hygiene.
- Base compartment consists of an electric standard oven with thick oven door for heat insulation, positioned beneath the base plate.
- Stainless steel oven chamber with 3 levels of runners to accommodate 2/1 GN shelves (2 steam pans).
- Oven thermostat adjustable from 140 °C to 300 °C.
- IPx4 water protection.

Construction

- All exterior panels in Stainless Steel with Scotch Brite finishing.
- One piece pressed 1.5 mm work top in Stainless steel.
- Model has right-angled side edges to allow flush fitting joints between units, eliminating gaps and possible dirt traps.

Sustainability

- Energy regulation of each zone.

APPROVAL: _____

Included Accessories

- 1 of GN2/1 chrome grid for static oven PNC 164250

- Large handrail - portioning shelf, 800mm PNC 216186

Optional Accessories

- GN2/1 chrome grid for static oven PNC 164250
- Junction sealing kit PNC 206086
- Kit 4 wheels - 2 swivelling with brake - it is mandatory to install Base support and wheels PNC 206135
- Flanged feet kit PNC 206136
- Frontal kicking strip for concrete installation, 800mm PNC 206148
- Frontal kicking strip for concrete installation, 1000mm PNC 206150
- Frontal kicking strip for concrete installation, 1200mm PNC 206151
- Frontal kicking strip for concrete installation, 1600mm PNC 206152
- Frontal kicking strip, 800mm (not for refr-freezer base) PNC 206176
- Frontal kicking strip, 1000mm (not for refr-freezer base) PNC 206177
- Frontal kicking strip, 1200mm (not for refr-freezer base) PNC 206178
- Frontal kicking strip, 1600mm (not for refr-freezer base) PNC 206179
- Kit 4 feet for concrete installation (not for 900 line free standing grill) PNC 206210
- Pair of side kicking strips PNC 206249
- Pair of side kicking strips for concrete installation PNC 206265
- Water column extension for 700 line PNC 206291
- Chimney upstand, 800mm PNC 206304
- Right and left side handrails PNC 206307
- Back handrail 800 mm PNC 206308
- Base support for feet or wheels - 800mm (700/900) PNC 206367
- Base support for feet or wheels - 1200mm (700/900) PNC 206368
- Base support for feet or wheels - 1600mm (700/900) PNC 206369
- Base support for feet or wheels - 2000mm (700/900) PNC 206370
- Rear paneling - 800mm (700/900) PNC 206374
- Rear paneling - 1000mm (700/900) PNC 206375
- Rear paneling - 1200mm (700/900) PNC 206376
- Chimney grid net, 400mm (700XP/900) PNC 206400
- Stainless steel grids with drain shape for free standing wide top grills (700XP) PNC 206415
- 2 side covering panels for free standing appliances PNC 216000
- Frontal handrail, 800mm PNC 216047
- Frontal handrail, 1200mm PNC 216049
- Frontal handrail, 1600mm PNC 216050

Front

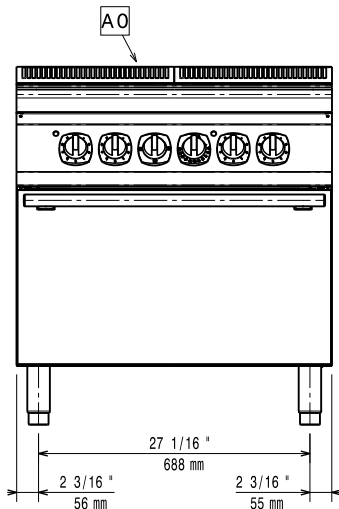

Side

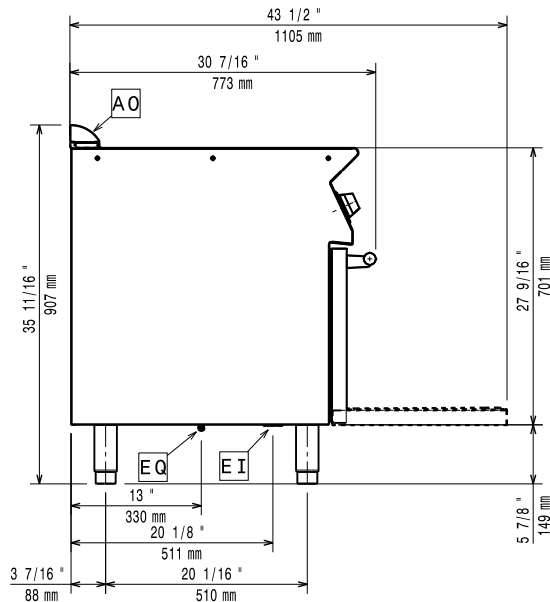

EI = Electrical inlet (power)
 EQ = Equipotential screw

Top

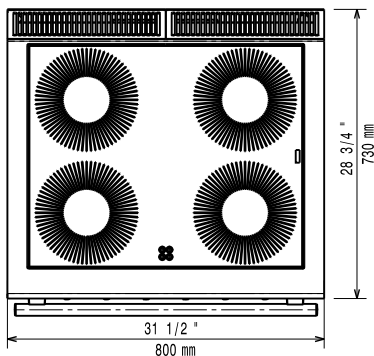

Electric

Supply voltage:

380-400 V/3N ph/50/60 Hz

371026 (E7IREH40E0)

Total Watts:

14.8 kW

Predisposed for:

380-400V 3N~ 50/60Hz
 13,6-14,8kW

Key Information:

Front Plates Power:

2.2 - 2.2 kW

Back Plates Power:

2.2 - 2.2 kW

Front Plates dimensions:

Ø 230 Ø 230

Back Plates dimensions:

Ø 230 Ø 230

Oven working Temperature:

140 °C MIN; 300 °C MAX

Oven Cavity Dimensions

(width):

540 mm

Oven Cavity Dimensions

(height):

300 mm

Oven Cavity Dimensions

(depth):

650 mm

External dimensions, Width:

800 mm

External dimensions, Depth:

730 mm

External dimensions, Height:

850 mm

Net weight:

83 kg

Shipping weight:

97 kg

Shipping height:

1080 mm

Shipping width:

820 mm

Shipping depth:

860 mm

Shipping volume:

0.76 m³

If appliance is set up or next to or against temperature sensitive furniture or similar, a safety gap of approximately 150 mm should be maintained or some form of heat insulation fitted.

Certification group:

N7CIE