



**Electrolux**  
PROFESSIONAL

**Modular Cooking Range Line  
700XP 4 Zone Electric Infrared  
Cooking Top Range**

ITEM # \_\_\_\_\_

MODEL # \_\_\_\_\_

NAME # \_\_\_\_\_

SIS # \_\_\_\_\_

AIA # \_\_\_\_\_



- |                     |  |
|---------------------|--|
| 371025 (E7IREH4000) | 4-zone (2,2 kW each)<br>Infrared Cooking Top |
| 371134 (E7IREH400N) | 4-zone (2,2 kW each)<br>Infrared Cooking Top |

**Short Form Specification**

Item No. \_\_\_\_\_

Ceramic glass top cooking surface 6 mm thick, lying flush to the stainless steel frame for smooth pan movement and easier cleaning. Completely sealed infrared cooking top surface to prevent liquid infiltration. Exterior panels in stainless steel with Scotch Brite finish. One piece pressed work top in 1.5 mm thick stainless steel. Right-angled side edges to allow flush-fitting junction between units.

**Main Features**

- Ceramic glass top cooking surface with 4 infrared heating zones 6 mm thick.
- The circular concentric heating sections measuring 230 mm give uniform heat also to the largest pan.
- The cooking top is sealed to prevent infiltration inside the unit.
- Warning light to indicate residual surface heat.
- Immediate heat transfer from cooking top to pan.
- Low heat dissipation to the kitchen.
- Heating via ultra high powered heating elements.
- The smooth glass-ceramic surface can be quickly and easily cleaned, thus providing maximum hygiene.
- IPx4 water protection.
- Suitable for countertop installation.

**Construction**

- All exterior panels in Stainless Steel with Scotch Brite finishing.
- One piece pressed 1.5 mm work top in Stainless steel.
- Model has right-angled side edges to allow flush fitting joints between units, eliminating gaps and possible dirt traps.

**Sustainability**

- Energy regulation of each zone.



APPROVAL: \_\_\_\_\_



Experience the Excellence  
[www.electroluxprofessional.com](http://www.electroluxprofessional.com)

### Optional Accessories

- Junction sealing kit PNC 206086
- Support for bridge type installation, 800mm PNC 206137
- Support for bridge type installation, 1000mm PNC 206138
- Support for bridge type installation, 1200mm PNC 206139
- Support for bridge type installation, 1400mm PNC 206140
- Support for bridge type installation, 1600mm PNC 206141
- Water column extension for 700 line PNC 206291
- Chimney upstand, 800mm PNC 206304
- Right and left side handrails PNC 206307
- Back handrail 800 mm PNC 206308
- Chimney grid net, 400mm (700XP/900) PNC 206400
- Stainless steel grids for free standing wide grills (700XP) (only for 371134) PNC 206414
- Scraper for grids with drainage channels - top grills (only for 371025) PNC 206421
- Frontal handrail, 800mm PNC 216047
- Frontal handrail, 1200mm PNC 216049
- Frontal handrail, 1600mm PNC 216050
- Large handrail - portioning shelf, 800mm PNC 216186
- 2 side covering panels for top appliances PNC 216277

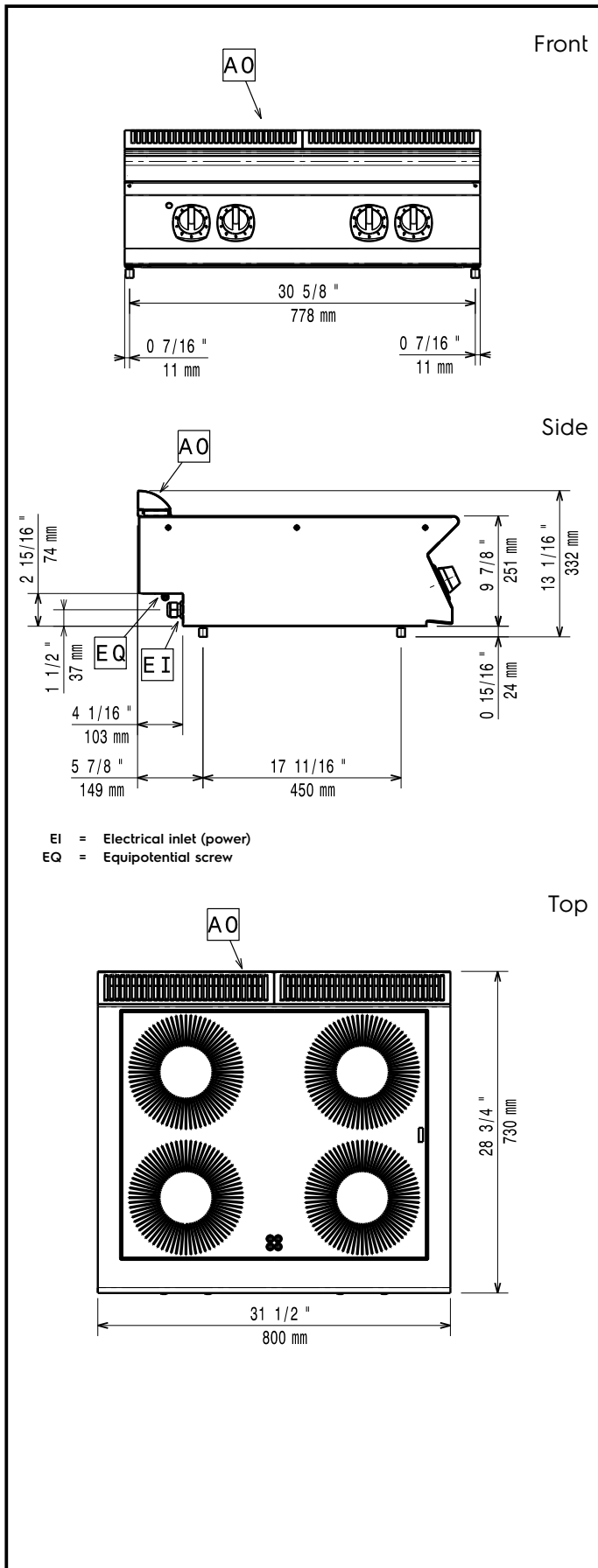

## Electric

### Supply voltage:

371025 (E7IREH4000)

380-400 V/3N ph/50/60 Hz

371134 (E7IREH400N)

230 V/3 ph/50/60 Hz

### Total Watts:

8.8 kW

### Predisposed for:

371025 (E7IREH4000)

380-400V 3N- 50/60Hz  
7,4-8,8kW

## Key Information:

### Front Plates Power:

2.2 - 2.2 kW

### Back Plates Power:

2.2 - 2.2 kW

### Front Plates dimensions:

Ø 230 Ø 230

### Back Plates dimensions:

Ø 230 Ø 230

### External dimensions, Width:

800 mm

### External dimensions, Depth:

730 mm

### External dimensions, Height:

250 mm

### Net weight:

35 kg

### Shipping weight:

371025 (E7IREH4000)

42 kg

371134 (E7IREH400N)

41 kg

### Shipping height:

371025 (E7IREH4000)

530 mm

371134 (E7IREH400N)

540 mm

### Shipping width:

371025 (E7IREH4000)

820 mm

371134 (E7IREH400N)

830 mm

### Shipping depth:

371025 (E7IREH4000)

860 mm

371134 (E7IREH400N)

850 mm

### Shipping volume:

371025 (E7IREH4000)

0.37 m<sup>3</sup>

371134 (E7IREH400N)

0.38 m<sup>3</sup>

If appliance is set up or next to or against temperature sensitive furniture or similar, a safety gap of approximately 150 mm should be maintained or some form of heat insulation fitted.

### Certification group:

371025 (E7IREH4000)

N7CIE

371134 (E7IREH400N)

NIR78