



**Electrolux**  
PROFESSIONAL

**Modular Cooking Range Line  
700XP Freestanding Electric  
Boiling Pan 60lt indirect heat**

ITEM # \_\_\_\_\_

MODEL # \_\_\_\_\_

NAME # \_\_\_\_\_

SIS # \_\_\_\_\_

AIA # \_\_\_\_\_



371272 (E7BSEHINFO)

60-lt indirect electric Boiling  
Pan with pressure switch

**Short Form Specification**

Item No. \_\_\_\_\_

To be installed on height adjustable feet in stainless steel. High efficiency heating elements (9.4 kW). Temperature is controlled by a power regulator; heating elements with temperature limiter. Exterior panels in stainless steel with Scotch Brite finish. One piece pressed work top in 1.5 mm thick stainless steel. Right-angled side edges to allow flush-fitting junction between units.

**Main Features**

- Kettle is suitable to cook, sauté or poach all kinds of produce.
- Produce is uniformly heated in the base and side walls of the kettle by an indirect heating system that uses integrally generated saturated steam at a temperature of 110° C in the jacket.
- Pressed cooking vessel and lid in 316 AISI Stainless steel.
- Unit to feature high efficiency heating elements (9.4 kW) with energy control and temperature limiter.
- External valve allows to manually evacuate excess air accumulated in the jacket during heating phase.
- Appliance is IPX4 water resistance certified.
- Solenoid valve to refill with hot and cold water.
- Safety valve avoids overpressure of the steam in the jacket.
- No overshooting of cooking temperatures, fast reaction.
- Large capacity drain tap enables precise portioning of the discharged food, especially small quantities.
- Firmly fitting cover to reduce cooking time and save energy costs.
- Ergonomic: unique ratio vessel diameter and height; depth facilitates stirring and gentle food handling.
- Discharge tube and tap are very easy to clean from outside.
- Smooth large surfaces, easy access for cleaning.
- Pressure switch control monitors energy and water consumption.
- Exterior panels in Stainless Steel with Scotch Brite finish.
- One piece pressed 1.5 mm work top in Stainless steel.
- Model has right-angled side edges to allow flush fitting joints between units, eliminating gaps and possible dirt traps.
- Unit delivered with four 50 mm legs in stainless steel as standard (all round Stainless steel kick plates as option).

**Construction**

- All exterior panels in Stainless Steel with Scotch Brite finishing.
- One piece pressed 1.5 mm work top in Stainless steel.
- Model has right-angled side edges to allow flush fitting joints between units, eliminating gaps and possible dirt traps.
- IPx4 water protection.

**Sustainability**

- Closed heating system – no waste of energy.
- Firmly fitting cover to reduce cooking time and save energy costs.
- Pressure switch control monitors energy and water consumption.



APPROVAL: \_\_\_\_\_



Experience the Excellence  
[www.electroluxprofessional.com](http://www.electroluxprofessional.com)

### Optional Accessories

- Junction sealing kit PNC 206086
- Kit 4 wheels - 2 swivelling with brake - it is mandatory to install Base support and wheels PNC 206135
- Flanged feet kit PNC 206136
- Frontal kicking strip for concrete installation, 400mm PNC 206147
- Frontal kicking strip for concrete installation, 800mm PNC 206148
- Frontal kicking strip for concrete installation, 1000mm PNC 206150
- Frontal kicking strip for concrete installation, 1200mm PNC 206151
- Frontal kicking strip for concrete installation, 1600mm PNC 206152
- Frontal kicking strip, 800mm (not for refr-freezer base) PNC 206176
- Frontal kicking strip, 1000mm (not for refr-freezer base) PNC 206177
- Frontal kicking strip, 1200mm (not for refr-freezer base) PNC 206178
- Frontal kicking strip, 1600mm (not for refr-freezer base) PNC 206179
- Kit 4 feet for concrete installation (not for 900 line free standing grill) PNC 206210
- Pair of side kicking strips PNC 206249
- Pair of side kicking strips for concrete installation PNC 206265
- Chimney upstand, 800mm PNC 206304
- Right and left side handrails PNC 206307
- Back handrail 800 mm PNC 206308
- Base support for feet or wheels - 400mm (700/900) PNC 206366
- Base support for feet or wheels - 800mm (700/900) PNC 206367
- Base support for feet or wheels - 1200mm (700/900) PNC 206368
- Base support for feet or wheels - 1600mm (700/900) PNC 206369
- Base support for feet or wheels - 2000mm (700/900) PNC 206370
- Rear paneling - 800mm (700/900) PNC 206374
- Rear paneling - 1000mm (700/900) PNC 206375
- Rear paneling - 1200mm (700/900) PNC 206376
- Chimney grid net, 400mm (700XP/900) PNC 206400
- 2 side covering panels for free standing appliances PNC 216000
- Frontal handrail, 800mm PNC 216047
- Frontal handrail, 1200mm PNC 216049
- Large handrail - portioning shelf, 800mm PNC 216186
- 1-section noodle basket for 60lt boiling pans PNC 921626
- Trolley with lifting & removable tank PNC 922403
- Measuring rod for 60 l Boiling Pan PNC 927000

Front

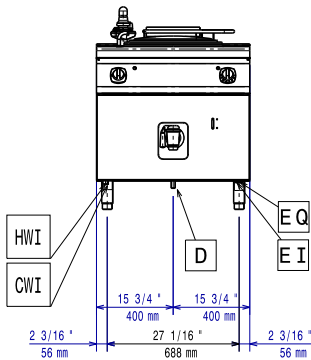

Side

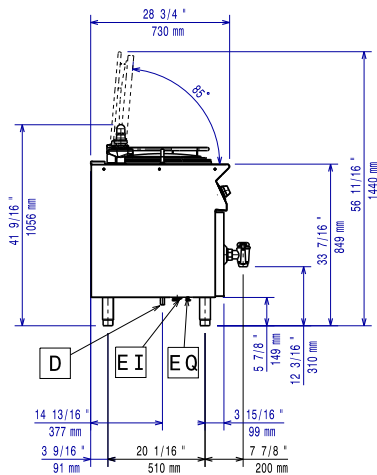

- CWI = Cold Water inlet 1 (cleaning)
- D = Drain
- EI = Electrical inlet (power)
- HWI = Hot water inlet

Top

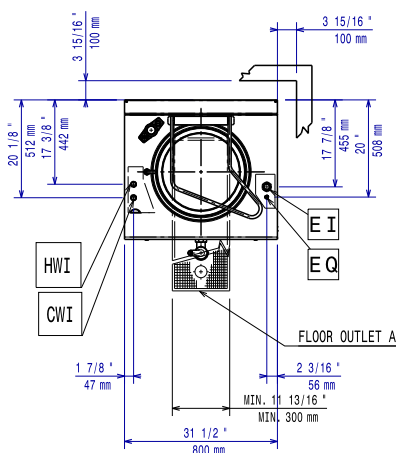

### Electric

#### Supply voltage:

371272 (E7BSEHINF0)

400 V/3N ph/50/60 Hz

#### Total Watts:

9.4 kW

380-400V 3N- 50/60Hz

#### Predisposed for:

8,5-9,4kW

### Water:

#### Water drain outlet size:

1"1/2

### Key Information:

#### Pan useful capacity:

60 lt

#### Vessel (round) diameter:

420 mm

#### Net weight:

100 kg

#### Shipping weight:

88 kg

#### Shipping height:

1140 mm

#### Shipping width:

900 mm

#### Shipping depth:

920 mm

#### Shipping volume:

 0.94 m<sup>3</sup>

No clearance needed on rear sides of unit if wall is of non combustible type. If wall is combustible, minimum 50 mm wall clearance should be maintained.

#### Certification group:

N7PE