



Modular Cooking Range Line 700XP Full Module Gas PowerGrill Top

ITEM # _____

MODEL # _____

NAME # _____

SIS # _____

AIA # _____



371043 (E7GRGHGC0P)

Full module gas PowerGrill
Top - HP

Short Form Specification

Item No. _____

Unit to be Electrolux Professional 700XP Full Module Gas PowerGrill top. Unit to have high efficiency 14 kW Stainless steel gas burners with flame failure device, optimized combustion and protected pilot light. Suitable for natural gas or LPG. Unit to be installed on open base installations, bridging supports or cantilever systems. Cooking surface grids to be of cast iron, easily removable for cleaning. Exterior panels of unit in Stainless steel with Scotch Brite finish. One piece pressed work top in 1.5 mm thick Stainless steel. Unit has right-angled side edges to allow flush-fitting junction between units.

Main Features

- Unit to be mounted on open base cupboards, bridging supports or cantilever systems.
- Stainless steel burners with flame failure device, optimized combustion and protected pilot light.
- AISI 441 stainless steel deflective shields located below the radiants prevent burners from clogging, minimize flare ups and ensure even heat distribution (PATENT US9591947B2 and related family).
- Dishwasher-safe radiants removable without the use of tools to facilitate cleaning.
- Stainless steel high splash guards on the rear and sides of cooking surface. Splash guards can be easily removed for cleaning and are dishwasher-safe.
- Cooking grids made in highly resistant enameled cast iron for easy cleaning.
- Suitable for countertop installation.

Construction

- All exterior panels in Stainless Steel with Scotch Brite finishing.
- One piece pressed 1.5 mm work top in Stainless steel.
- Model has right-angled side edges to allow flush fitting joints between units, eliminating gaps and possible dirt traps.
- IPx4 water protection.

APPROVAL: _____



Experience the Excellence
www.electroluxprofessional.com

Optional Accessories

- Junction sealing kit PNC 206086
- Draught diverter, 150 mm diameter PNC 206132
- Matching ring for flue condenser, 150 mm diameter PNC 206133
- Support for bridge type installation, 800mm PNC 206137
- Support for bridge type installation, 1000mm PNC 206138
- Support for bridge type installation, 1200mm PNC 206139
- Support for bridge type installation, 1600mm PNC 206141
- Flue condenser for 1 module, 150 mm diameter PNC 206246
- Right and left side handrails PNC 206307
- Back handrail 800 mm PNC 206308
- Scraper kit with hooks for HP grills PNC 206347
- Base support for feet or wheels - 1200mm (700/900) PNC 206368
- Kit G.25.3 (NI) gas nozzles for 700 and 900 gas grills (standard and HP) PNC 206462
- Frontal handrail, 800mm PNC 216047
- Frontal handrail, 1200mm PNC 216049
- Frontal handrail, 1600mm PNC 216050
- Large handrail - portioning shelf, 800mm PNC 216186
- 2 side covering panels for top appliances PNC 216277
- Pressure regulator for gas units PNC 927225

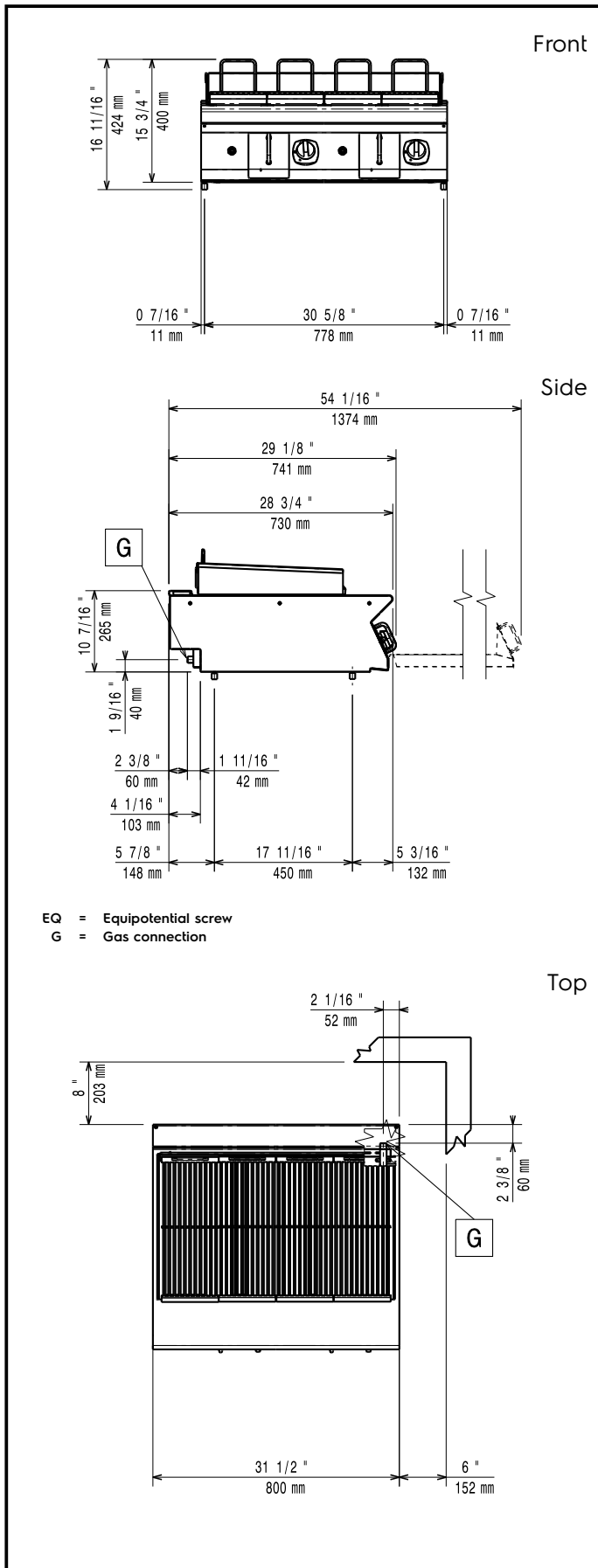

Gas

Gas Power:	371043 (E7GRGHGC0P)	14 kW
Standard gas delivery:		Natural Gas G20 (20mbar)
Gas Type Option:		
Gas Inlet:		1/2"

Key Information:

Cooking surface width:	742 mm
Cooking surface depth:	472 mm
Net weight:	60 kg
Shipping weight:	88 kg
Shipping height:	580 mm
Shipping width:	820 mm
Shipping depth:	860 mm
Shipping volume:	0.41 m ³

If appliance is set up or next to or against temperature sensitive furniture or similar, a safety gap of approximately 150 mm should be maintained or some form of heat insulation fitted.

Certification group: N7EGG