



Electrolux
PROFESSIONAL

**Modular Cooking Range Line
700XP One Well Freestanding
Electronic Fryer 15 liter**

ITEM # _____

MODEL # _____

NAME # _____

SIS # _____

AIA # _____



371083 (E7FREDIGFP)

15-lt electric programmable Fryer free standing with 1 "V" shape well (external heating elements) and 2 baskets

Short Form Specification

Item No. _____

To be installed on height adjustable feet in stainless steel. High efficiency infrared heating elements (10kW) attached to the outside of the well. Deep drawn V-shaped well. Oil drains through a tap into an external drainage container (not included). Electronic programmable control. Automatic basket lifting. Melting function to safely heat-up solid shortening used to fry products. Exterior panels in stainless steel with Scotch Brite finish. One piece pressed work top in 1.5 mm thick stainless steel. Right-angled side edges to allow flush-fitting junction between units.

Main Features

- Unit to be mounted on height adjustable feet in stainless steel.
- Deep drawn V-Shaped well.
- Electronic control panel allows to memorize 5 standard programs (HACCP compliant) with 5 temperatures and 2 lifting times per program.
- Automatic basket lifting system: 2 independently controlled lifters
- High efficiency infrared heating elements are attached to the outside of the well.
- Thermostatic regulation of oil temperature up to a maximum of 185 °C.
- Built-in smart electronic control system to monitor the temperature during frying to guarantee the safety of the process.
- Overheat protection thermostat as standard on all units.
- All major compartments located in front of unit for ease of maintenance.
- IPx4 water protection.
- Optional portable oil quality monitoring tool (code 9B8081) for efficient oil management.
- Oil drains through a tap into into an external drainage container (not included).

Construction

- Interior of well with rounded corners for ease of cleaning.
- All exterior panels in Stainless Steel with Scotch Brite finishing.
- One piece pressed 1.5 mm work top in Stainless steel.
- Model has right-angled side edges to allow flush fitting joints between units, eliminating gaps and possible dirt traps.

Sustainability



- This model is compliant with Swiss Energy Efficiency Ordinance (730.02).

APPROVAL: _____



Experience the Excellence
www.electroluxprofessional.com

Included Accessories

- 1 of Door for open base cupboard PNC 206350
- 1 of 2 half size baskets for 12, 14 and 15lt fryers PNC 921692

Optional Accessories

- Junction sealing kit PNC 206086
- Flanged feet kit PNC 206136
- Support for bridge type installation, 800mm PNC 206137
- Frontal kicking strip, 400mm (not for refr-freezer base) PNC 206175
- Frontal kicking strip, 800mm (not for refr-freezer base) PNC 206176
- Frontal kicking strip, 1000mm (not for refr-freezer base) PNC 206177
- Frontal kicking strip, 1200mm (not for refr-freezer base) PNC 206178
- Frontal kicking strip, 1600mm (not for refr-freezer base) PNC 206179
- Full size basket with holder for automatic programmable fryer PNC 206196
- Sediment tray for 15lt fryers PNC 206235
- Pair of side kicking strips PNC 206249
- Oil drain pipe for 15lt free standing fryer PNC 206301
- Right and left side handrails PNC 206307
- Back handrail 800 mm PNC 206308
- Door for open base cupboard PNC 206350
- Base support for feet or wheels - 400mm (700/900) PNC 206366
- Base support for feet or wheels - 800mm (700/900) PNC 206367
- Base support for feet or wheels - 1200mm (700/900) PNC 206368
- Base support for feet or wheels - 1600mm (700/900) PNC 206369
- Base support for feet or wheels - 2000mm (700/900) PNC 206370
- Rear paneling - 600mm (700/900XP) PNC 206373
- Rear paneling - 800mm (700/900) PNC 206374
- Rear paneling - 1000mm (700/900) PNC 206375
- Rear paneling - 1200mm (700/900) PNC 206376
- Base support for feet or wheels - 600mm (700/900) PNC 206431
- 2 side covering panels for free standing appliances PNC 216000
- Full size basket for 14 and 15lt free standing fryers PNC 921691
- 2 half size baskets for 12, 14 and 15lt fryers PNC 921692
- Unclogging rod for 15lt fryers drainage pipe PNC 921695
- Deflector for floured products for 15lt fryers PNC 921696

Front

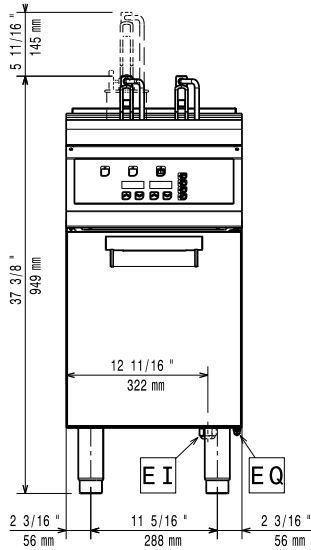

Side

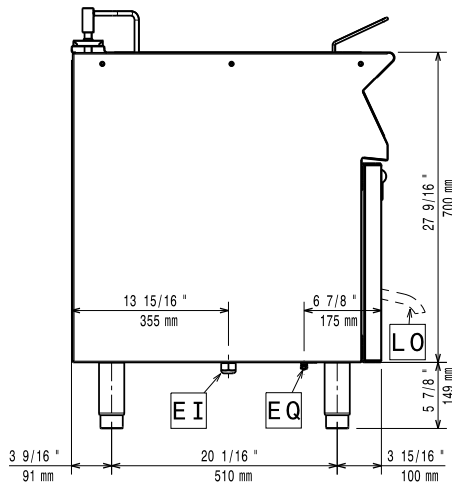

EI = Electrical inlet (power)
 EQ = Equipotential screw

Top

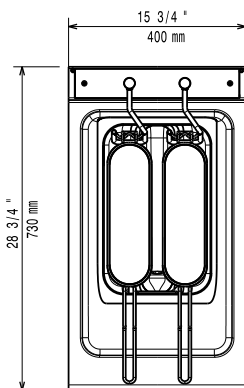

Electric

Supply voltage:

380-400 V/3N ph/50/60 Hz

371083 (E7FRED1GFP)

Total Watts:

10 kW

Predisposed for:

380-400V 3N~ 50/60Hz
 9-10kW

Key Information:

Usable well dimensions
 (width):

240 mm

Usable well dimensions
 (height):

505 mm

Usable well dimensions
 (depth):

380 mm

Well capacity:

13 lt MIN; 15 lt MAX

Thermostat Range:

105 °C MIN; 185 °C MAX

Net weight:

59 kg

Shipping weight:

68 kg

Shipping height:

1140 mm

Shipping width:

480 mm

Shipping depth:

820 mm

Shipping volume:

0.45 m³

If appliance is set up or next to or against temperature sensitive furniture or similar, a safety gap of approximately 150 mm should be maintained or some form of heat insulation fitted.

Certification group:

N7FE1