



# Modular Cooking Range Line 700XP One Well Electric Fryer Top 12 liter

ITEM # \_\_\_\_\_

MODEL # \_\_\_\_\_

NAME # \_\_\_\_\_

SIS # \_\_\_\_\_

AIA # \_\_\_\_\_



- 371079 (E7FREDIE00) 12-lt electric Fryer Top with 1 well and 1 basket, internal heating elements
- 371142 (E7FREDIE0N) 12-lt electric Fryer Top with 1 well and 1 basket, internal heating elements

## Short Form Specification

Item No. \_\_\_\_\_

Unit to be Electrolux Professional 700XP One 12 It well Electric Fryer Top. Unit to have high efficiency tilting incoloy heating elements inside the well. Electric characteristics to be \_\_\_ 400 V or \_\_\_ 230 V three phase. Unit to be installed on open base installations, bridging supports or cantilever systems. Unit to have deep drawn well. Oil drains through a tap on the front. Exterior panels of unit in Stainless steel with Scotch Brite finish. One piece pressed work top in 1.5 mm thick Stainless steel. Unit has right-angled side edges to allow flush-fitting junction between units.

## Main Features

- Unit to be mounted on open base cupboards, bridging supports or cantilever systems.
- Thermostatic regulation of oil temperature up to a maximum of 185 °C.
- Overheat protection thermostat as standard on all units.
- Oil drains through a tap positioned on the front the well.
- All major compartments located in front of unit for ease of maintenance.
- IPx4 water protection.
- Incoloy armoured heating elements located inside the well can be lifted up for easier cleaning.
- Optional portable oil quality monitoring tool (code 9B8081) for efficient oil management.
- Suitable for countertop installation.

## Construction

- All exterior panels in Stainless Steel with Scotch Brite finishing.
- One piece pressed 1.5 mm work top in Stainless steel.
- Model has right-angled side edges to allow flush fitting joints between units, eliminating gaps and possible dirt traps.
- Interior of well with rounded corners for ease of cleaning.

APPROVAL: \_\_\_\_\_



### Included Accessories

- 1 of Basket for 12lt electric fryer tops PNC 921629

### Optional Accessories

- Junction sealing kit PNC 206086
- Support for bridge type installation, 800mm PNC 206137
- Support for bridge type installation, 1000mm PNC 206138
- Support for bridge type installation, 1200mm PNC 206139
- Support for bridge type installation, 1400mm PNC 206140
- Support for bridge type installation, 1600mm PNC 206141
- Support for bridge type installation, 400mm PNC 206154
- Chimney upstand, 400mm PNC 206303
- Right and left side handrails PNC 206307
- Back handrail 800 mm PNC 206308
- 2 drawers for refrigerated base (only for 371142) PNC 206351
- Chimney grid net, 400mm (700XP/900) PNC 206400
- 2 side covering panels for top appliances PNC 216277
- Basket for 12lt electric fryer tops PNC 921629
- Water additive against corrosion for indirect boiling pans (only for 371079) PNC 927222

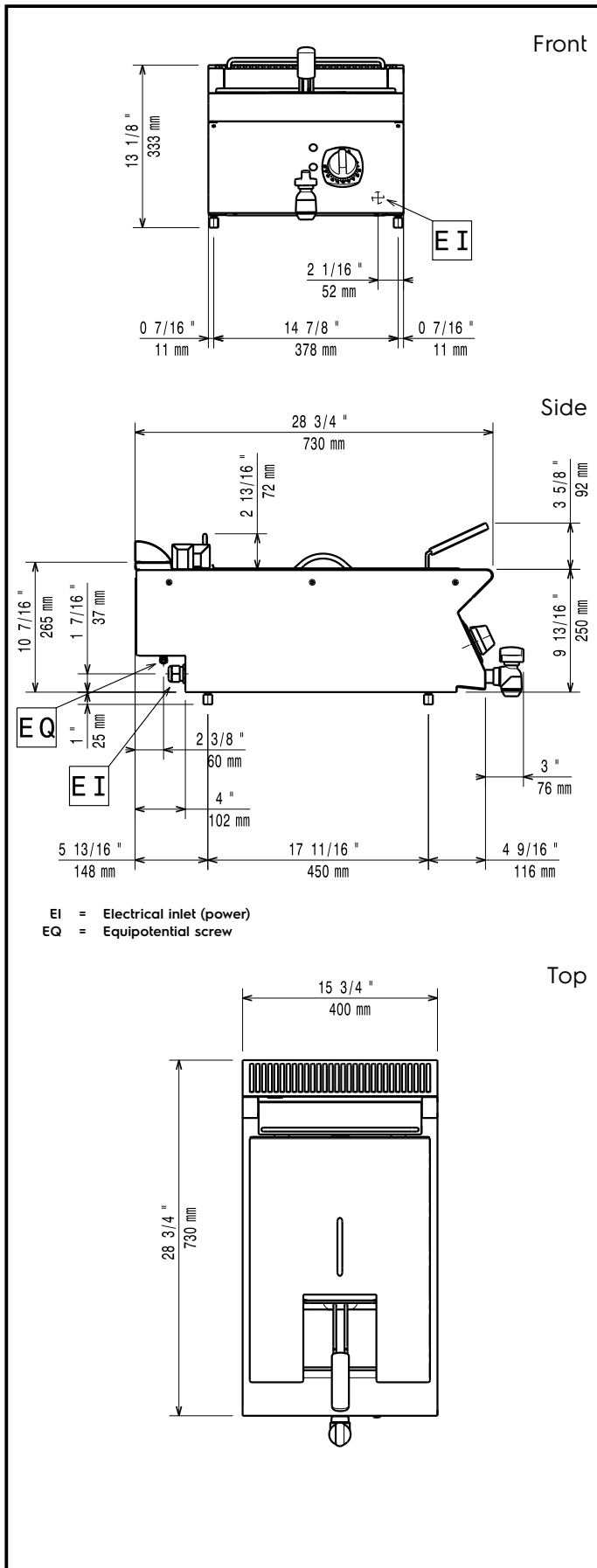

### Electric

#### Supply voltage:

371079 (E7FREDIE00)

380-400 V/3N ph/50/60 Hz

371142 (E7FREDIE0N)

230 V/3 ph/50/60 Hz

#### Total Watts:

8.7 kW

#### Predisposed for:

371079 (E7FREDIE00)

380-400V 3N- 50/60Hz  
 7,9-8,7kW

### Key Information:

#### Usable well dimensions (width):

240 mm

#### Usable well dimensions (height):

235 mm

#### Usable well dimensions (depth):

420 mm

#### Well capacity:

10 lt MIN; 12 lt MAX

#### Thermostat Range:

105 °C MIN; 185 °C MAX

#### Net weight:

25 kg

#### Shipping weight:

371079 (E7FREDIE00)

30 kg

371142 (E7FREDIE0N)

32 kg

#### Shipping height:

371079 (E7FREDIE00)

530 mm

371142 (E7FREDIE0N)

540 mm

#### Shipping width:

460 mm

#### Shipping depth:

820 mm

#### Shipping volume:

0.2 m<sup>3</sup>

If appliance is set up or next to or against temperature sensitive furniture or similar, a safety gap of approximately 150 mm should be maintained or some form of heat insulation fitted.

#### Certification group:

371079 (E7FREDIE00)

EF17112

371142 (E7FREDIE0N)

N7FE2